

SKF Agri Solutions

Bearings, seals, mechatronics and lubrication

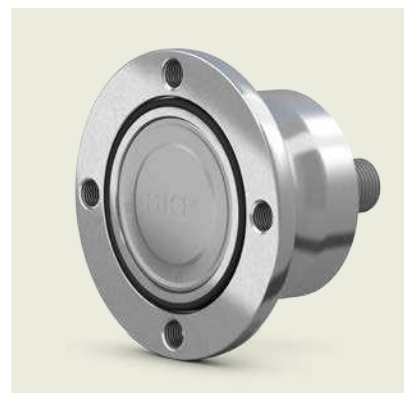

INCREASE
PRODUCTIVITY
UP TO
150%



skf.com | lincolnindustrial.com

® SKF and Lincoln are registered trademarks of the SKF Group.

© SKF Group 2017

The contents of this publication are the copyright of the publisher and may not be reproduced (even extracts) unless prior written permission is granted. Every care has been taken to ensure the accuracy of the information contained in this publication but no liability can be accepted for any loss or damage whether direct, indirect or consequential arising out of the use of the information contained herein.

PUB 46/P2 17659 EN · November 2017

Certain image(s) used under license from Shutterstock.com.

Table of contents

Challenges in the agricultural industry	5
To meet the challenges	5
SKF Agri Solutions – customer testimonials	6
Solutions	8
SKF Explorer tapered roller bearings	8
Seals	9
Tractors	10
Application challenges	10
SKF Agri Solutions – tractors	10
Tillage	16
Application challenges	16
Typical conditions for independent disc applications	16
SKF Agri Solutions – independent discs	16
Conditions for seedbed finisher applications	17
SKF Agri Solutions – seedbed finishers	17
Seeding	22
Application challenges	22
Conditions for opener disc applications	23
Harvesting	26
Application challenges	26
SKF Agri Solutions benefits – combine harvesters	26
Baling	36
Application challenges	36
SKF Agri Solutions benefits – balers	36
Attachment and trailer wheels	42
Implement wheel and walking beam of tillage and seeding machines	42
Lubrication solutions	44



REDUCE
UNPLANNED
DOWNTIME



Challenges in the agricultural industry

Today's farmers are under increasing pressure to stay productive at lower cost, yet with a reduced environmental footprint. This means that the demands on farm equipment are constantly increasing to accommodate faster operating speeds, more agile machines and increased loads. Due to the fact that the agricultural industry is very much controlled by the seasons with limited time windows for critical operations within the crop cycle, machines and tools need to be extremely reliable with high availability, especially during those intense periods of work. Hence, it is critical to reduce or eliminate both routine maintenance and unplanned downtime as far as possible. If not, both can be extremely costly in terms of lost production.

Irrespective of size, location, elevation, climate, soil structure and crop, all farm equipment must endure many of the same challenging and harsh conditions. Mud, dust, straw, stones, debris, and corrosive chemicals are just a few examples of the potential contaminants that the machinery needs to withstand. If not, the consequences of seal failure are two-fold; loss of lubricant to the environment and an insufficiently lubricated and contaminated bearing. Bearing damage (however caused) progressively reduces a farm's output and profitability, from a loss of precision and impaired operational functionality to a full in-service failure requiring significant time and expenditure to repair the machine and replace failed units. For OEMs, premature failures increase warranty costs and can damage customer relationships.

To meet the challenges

To help meet the challenges of modern farming it is important to understand the working conditions that the machinery is exposed to and the different elements of a design that will most effectively contribute to a successful solution. By drawing on expertise and experience in a range of technical areas, from bearings and seals to lubrication systems and mechatronics, SKF knows what it takes to develop and construct products that can withstand the harsh conditions out in the field. The SKF Agri Solutions products, that are tested both in house and on working farms, are designed to deliver a wide range of benefits to both equipment manufacturers and farmers:

- Reduced routine maintenance – re-lubrication free and/or minimum maintenance
- Improved equipment reliability and availability – integrated, unitised designs
- Higher yield – robust and precise operation
- Reduced environmental impact – higher efficiency and/or sealed for life units
- Fast delivery – through global parts availability

Thanks to SKF's wide expertise in a diverse range of technical areas, all stages of the crop cycle including tilling, seeding, harvesting, mowing and baling, can be supported with cost-effective solutions. Together with a global manufacturing footprint and dedicated distribution network, SKF is an ideal partner for international equipment manufacturers and a reliable source of parts for the local agriculture aftermarket.



SKF Agri Solutions – customer testimonials

OEM – SKF Agri Hub tillage

During testing:

“We’ve pulled our Norwood Kwik-Till machine 11-12 mph through the field and so far have covered 8 000 acres with zero bearing failures. That is truly exceptional!”

Dan Norwood

President
Norwood Sales Inc.
USA

OEM – Insert bearing for harvesting and tillage

“SKFY-bearings are premium products that deliver premium performance. That’s why we chose them in the first place, and why we don’t ever intend to switch.”

Javier López

C.E.O.
Industrias David
Spain

OEM – partnership

“We are looking to customer needs on a constant basis. For those customer needs, we go to engineering, develop new products that cope with these requirements. Customers don’t like downtime, maintenance is also a kind of downtime.

So they try to reduce that as much as possible. That’s why we want suppliers like SKF, who will reduce our customers’ downtime.”

Marcel Verhoeven

Combine Harvester Product Manager
New Holland

SKF Agri Hub tillage

“SKF Agri Hub has ensured continuous production with ease of mind and this is very comforting.”

Petrus Roux

Owner
Kromvlei Farm
South Africa

OEM – Partnership

“The machines are becoming more and more complicate so we have to improve the material that we use, the systems that make these machines easy to use for the operators, otherwise it is difficult to have success. Normally in the past years, the suppliers were giving us just components, but today they have to supply us and work with us to identify complete systems to integrate in our machines and develop together with our engineers to be more and more interesting for the market. So we need strong cooperation with experts and suppliers to solve the problems of each single system.

In this case SKF can help us in mechatronic, in bearings and mechanical systems to complete our machines with high-quality and cost effective solutions.”

Gianfranco Donadon ,
Technical director R&D,
Maschio Gaspardo

Farmer – SKF Agri Hub tillage

“My farm requires 40 days tillage a year – 30 in spring to prepare for the maize and 10 in autumn to prepare for the wheat. With the new solution there is no need to wash and lubricate the discs and I save half an hour a day. The work is done more quickly and easily. We drive at more than 20 km an hour and I have seen an improvement in the way the land is worked: with the old harrow the top speed was 7 or 8 km an hour. The old 2,5 metre harrow worked one hectare an hour, the new machine, which is still 2,5 metre covers two and half hectares an hour. The old 20 disc harrow required a 20 kilo can of grease each year, with this new solution I’ve eliminated greasing and washing.

In my job I’m in contact with nature every day and I’m pleased that with the new SKF solution I’m not polluting the land with grease anymore.”

– Farmer Italy

Farmer – five lip insert bearing for harvesting

“We have seen a significant change in quality – for the better. Now we harvest a whole season without replacing any bearings. It saves a lot of time that we are able to harvest without any downtime throughout the whole season. The new Y-bearings have given us more reliability and savings in man-hours. I warmly recommend them.”

Ole Madsen

Owner of Kjargaarden farm

SKF bearings were purchased via Kramp Denmark. Kramp is the biggest Agri specialized DD in Europe

OEM – partnership

“We have been designing and building corn harvesting machines for over sixty years. Customers are looking for increasingly advanced machines able to improve the production in less time and with higher quality. Olimac has focused most of its resources on technological research and innovation: this has enabled us to design and produce corn heads allowing for complete corn harvesting of every ear and kernel without any product loss. We buy bearings from SKF because SKF bearings guarantee high quality and high precision, superior to other suppliers'. They contribute to long life and great performance in our products.”

Lorenzo Carboni

Research & Development Director,
Olimac s.r.l.



SKF Explorer tapered roller bearings



SKF Explorer design

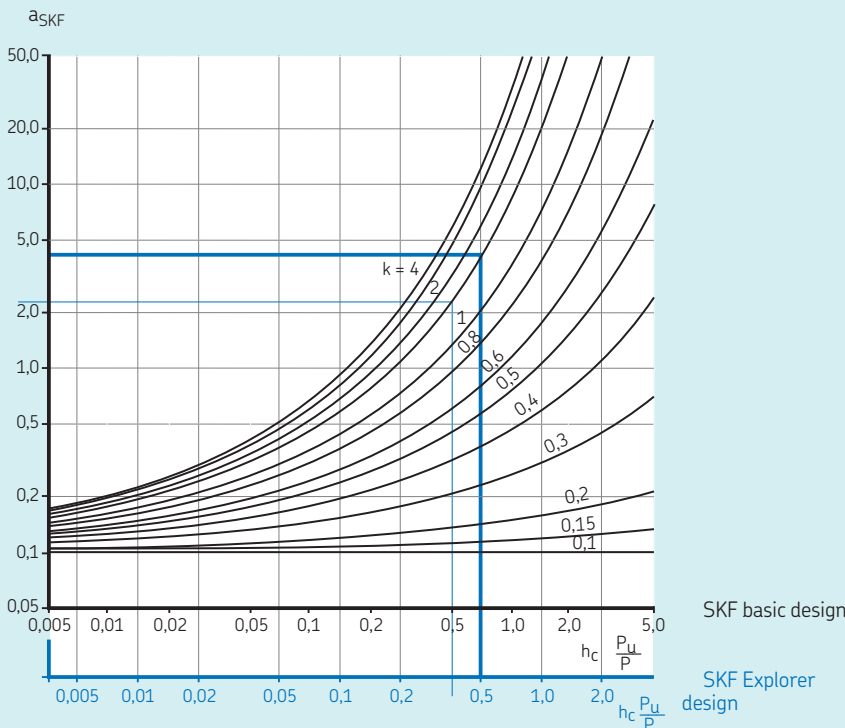





* The factor a_{SKF} represents the relationship between the fatigue load limit ratio (P_u/P), the lubrication condition (viscosity ratio κ) and the contamination level in the bearing (η_c).

SKF Explorer tapered roller bearings – get more uptime all the time

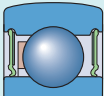
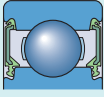
- Robustness
- Wear resistance
- Reliable in operation
- Long service intervals
- Contamination resistance
- Additional options include case hardened bearings and coatings

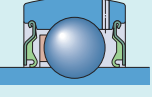
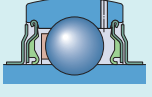
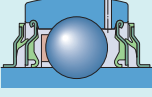
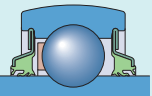
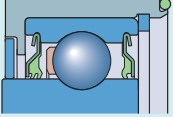
Seals

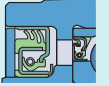
SKF seals			
Seal type	Seal cross section	Contamination	Machine
Single lip Deep groove ball bearing (RS1)		Low	Harvesting
Single lip Deep groove ball bearing (RSH)		Moderate	Harvesting
Single lip Agri Deep groove ball bearing (AAG)		Low	Harvesting
Single lip insert bearing		Moderate	Harvesting
Single lip insert bearing with flinger (F)		High	Harvesting
Double lip insert bearing with flinger (RF)		Severe	Harvesting, seeding
Five lip		Severe	Harvesting, seeding
Double lip with Labyrinth		Severe	Seeding
Cassette seal (R-safe)		Severe	Seeding, tillage
Mudblock seal		Maximum	Tillage
Mudblock seal and cassette seal		Maximum	Tillage

Tractors

Agricultural tractors are the work horses of the industry with drivetrain, engine, suspension and steering being key sub-systems. Safety, availability and productivity are the underlying forces driving many of the industry trends:

- Automation, smart functionality and power management
- Better efficiency, reduced frictional losses, lower fuel costs
- Increased power density and reliability
- Standardisation (consolidation of the powertrain)
- Improved comfort and safety

Application challenges

On-road time, travelling between locations, is time away from the field so allowing higher on-road speeds whilst maintaining a compact tractor design with tighter turning circles increases the proportion of time that these assets are truly productive. In addition, further challenges are:

- Long, intensive work periods
- Exposure to the elements and harsh ground conditions
- Reducing grease consumption
- Increasing productivity, efficiency and profitability

If key components are not designed for these kind of conditions, it can easily lead to damage and early life failure. Such events lower productivity, increase maintenance costs and reduce overall profitability.

SKF Agri Solutions – tractors

Among the many products especially developed to handle harsh conditions, SKF offers plain bearings and bushing (lubricant free), a range of radial ball and roller bearings, geared hub units and seals.

For steering and suspension, reliance on grease lubrication increases the maintenance costs and risks both crop contamination and disruption to the sensors that are increasingly a part of the digitilisation of farming. A lubricant and maintenance free spherical plain bearing or filament wound bushing provides a solution that will improve service life, reduce maintenance costs and avoid the potential grease contamination issues.

For drivetrain applications, a ready to mount flanged gear hub unit and the SKF pinion unit are two good examples of how to increase power density. Overall the design is focussed on maximising the productivity and the availability of the tractor.

The SKF Electronic parking brake will provide a solution to brake a tractor with CVT (Continuous variable transmission) in downhill conditions.

In the accompanying product tables, solutions for the key components of tractors are presented, covering axle, suspension, steering, power take off and engine ancillary parts.



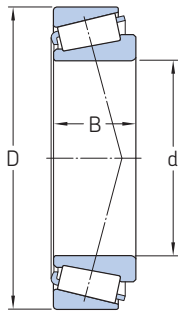

Tapered roller bearing

Designation	Key dimensions			Basic load ratings		Speed ratings	
	D	d	B	dynamic C	static C ₀	Reference speed	Limiting speed
–	mm			kN		r/min	
Non Driven wheel							
LM 67048/010	59,131	31,75	15,875	42,8	41,5	9 500	11 000
Gearbox							
32013 X/VB533	100	65	23	103	127	5 000	6 000
399 A/394 A/VB079	110	68,262	22	108	118	4 800	6 000
32210	90	50	24,75	101	100	6 000	7 500
387/382 A	96,838	57,15	21	99,9	102	5 600	6 700
30209	85	45	20,75	81,6	76,5	6 300	8 000
32013 X/VU1001	90	55	23	99,4	116	5 600	7 000
30205	52	25	16,25	38,1	33,5	11 000	13 000
32011 X	90	55	23	99,4	116	5 600	7 000
30211	100	50	22,75	111	106	5 300	6 700
33207	72	35	28	104	106	7 000	9 500
33113	110	65	35	175	208	4 800	5 600
30208	80	40	19,75	75,8	68	7 000	8 500
30207	72	35	18,25	63,2	56	8 000	9 500
HM 903249/2/210/2/	95,25	44,45	30,958	124	122	5 300	7 000
395 A/394 A	110	66,675	22	108	118	4 800	6 000
09067/09195	49,225	19,050	18,035	47,7	40	13 000	15 000
3984/2/3920/2	112,712	66,675	30,162	152	183	4 800	5 600
32309	100	45	38,25	173	170	5 300	7 000
30214	125	70	26,25	155	156	4 300	5 300
30215/CLN	130	75	27,25	171	176	4 000	5 000
1988/1922	57,150	28,575	19,845	58,2	55	10 000	12 000
LM 48548/510	65,088	34,925	18,034	58	57	8 500	10 000
32016 X	125	80	29	168	216	4 000	5 000
594 A/592 A	152,4	95,250	39,688	237	305	3 400	4 300

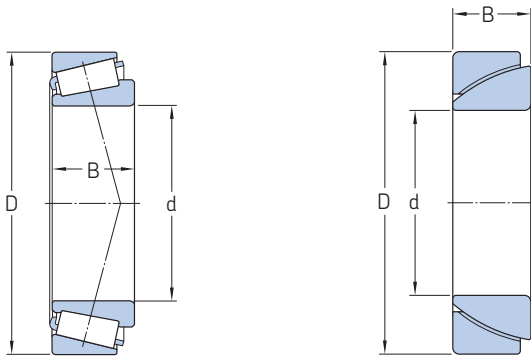

Designation	Key dimensions			Basic load ratings		Speed ratings		Seal type
	D	d	B	dynamic C	static C ₀	Reference speed	Limiting speed	
–	mm			kN		r/min		–
Front axle – tapered roller bearing								
BT1-0160	135	95	20	72,1	125	3 200	4 800	
32018 X	140	90	32	208	270	3 600	4 300	
Front axle – suspension pivot filament wound bushing								
BPF-0164	55	39,5	45					
Front axle – suspension pivot spherical plain bearing								
BLR-4504	222,25	139,8	133,98	1 730	5 200			LS-seals
BLR-0275 C	95	60	66	430	2 160			Special customized
Front axle / Half shaft – COMPACT Seals								
42x62x21.5 COM2 R	62 H8	42h8	21.5					
Kingpin – angular contact spherical plain bearing								
365049 CB	64,29	30,162	21,431	193	380			
365208 AA	80	40	24,75	355	585			
BLAB 367564 B	62	35	18	58,8	290			
Kingpin – spherical plain bearing								
BLRB 366481	42	24	23	50	250			
Final reduction / Wheel Ends – Mudblock seal								
70x95x14/15 MUD11 R	95H8	70h8	15/16			150	300	
90x120x15/16 MUD11 R	120H8	90h8	15/16			150	300	
130x160x15/16 MUD11 R	160H8	130h8	15/16			150	300	
133.46x183x15/16 MUD11 R	183H8	133.46h8	15/16			150	300	
140x170x15/16 MUD11 R	170H8	140h8	15/16			150	300	
145x175x15/16 MUD11 R	175H8	145h8	15/16			150	300	
150x180x15/16 MUD11 R	180H8	150h8	15/16			150	300	
158.75x200x15/16 MUD11 R	200H8	158.75	15/16			150	300	
165x190x15/16 MUD11R	190H8	165h8	15/16			150	300	
170x200x15/16 MUD11 R	200H8	170h8	15/16			150	300	
190x220x16/18 MUD11 R	220H8	190h8	16/18			150	300	
210x240x16/18 MUD11 R	240H8	210h8	16/18			150	300	Extended life

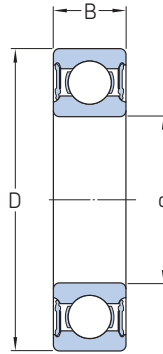
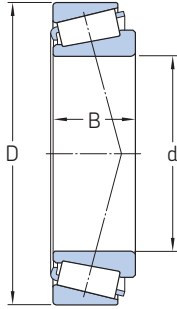

Designation	Key dimensions			Basic load ratings		Speed ratings		Seal type
	D	d	B	dynamic C	static C ₀	Reference speed	Limiting speed	
–	mm			kN		r/min		–
Rear axle pinion unit – tapered roller bearing								
T7FC 065/CL7C	130	65	37	194	216	3 800	5 000	
31308/CL7C	90	40	25,250	91,1	81,5	5 600	7 500	
32309 BR/CL7C	100	45	38,25	166	176	5 000	6 700	
33211/CL7CVB022	100	55	35	170	190	4 800	6 300	
32012 X/CL7C	95	60	23	101	122	5 300	6 700	
32313/68 BR/CL7AVC026	140	65	51	305	345	3 600	4 800	
M 802048/011/CL7C	82,55	41,275	26,543	91,2	91,5	6 700	8 000	
Engine variable fan drive – deep groove ball bearing								
6207 - 2RS2/C3HS0VT486	72	35	17	22,1	15,3	6 000		
6209 - 2RS2/C3HS0VT486	85	45	19	28,1	20,4	5 000		
6309 - 2RS2/C3HS0VT486	100	45	25	55,3	31,5	4 500		
6018 - 2RS2/C3HS0VT486	140	90	24	60,5	50	2 800		

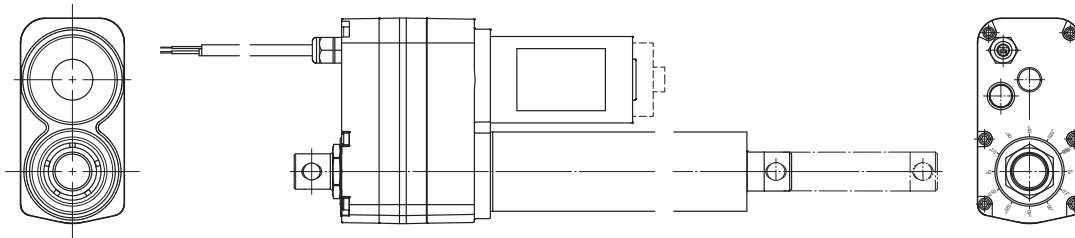

Example of designation

Load

Rated load
push/pull

Holding force
Max¹⁾

Max speed

Max stroke

Seal type

Example of designation	Rated load push/pull	Holding force Max ¹⁾	Max speed	Max stroke	Seal type
–	N		mm/s	mm	–

Engine hood - Lifter - Electro mechanical linear actuator

CAHB-22-F4E-3000500-BAAL0T-000	10 000	20 000	13	450	Brake for holding force 20 000 N, manual override, IP69K/66M with gore automotive vent, environmental validation, stroke self-limitation by built-in switches
CAHB-22-F3E-6100845-BAAL0T-000	10 000	20 000	22	610	

¹⁾ The Holding force is also depending the stroke length

A tractor's front axles are very close to the ground, making the lubrication points difficult to access. To manually lubricate them requires hours of working time that could be used more efficiently by driving the tractor in the field. Lincoln's Quicklub automatic lubrication system is easy to install or retrofit and helps to keep your machines running reliably throughout the season.

Lubrication solutions for tractors

HP-500W (See [page 44](#))
HP-500-SSV (See [page 44](#))
PF-VPBM (See [page 44](#))
QLS 401 (See [page 45](#))
P502 (See [page 46](#))
P203 (See [page 46](#))
KFA (See [page 47](#))
KFG (See [page 47](#))
SSV (See [page 48](#))
SSVD (See [page 48](#))
VPB (See [page 49](#))
VPK (See [page 50](#))



Tillage

Tillage is the first step of the agriculture process and is typically carried out twice per year, in spring and autumn. The purpose is to prepare the soil for new seed. This means to turn nutritious soil to the surface and to integrate crop residues to a lower layer of the soil to facilitate decay. Another important purpose for tillage is to break up the soil so that it will achieve the right balance of moisture and air in order to avoid soil erosion. This is done by using tillage discs to cut through the soil and seedbed finishers to then level and firm.

The potential gains for a farmer using the right components for tillage equipment can be significant; increase productivity by up to 150%, reduce cost of ownership by up to 30% and with the benefit of an easier installation or replacement.

Application challenges

- Very harsh environment: mud, water, dust and crop residues
- Tilting forces, shock loads and stone impacts
- Higher machine speeds (for higher productivity)
- Avoiding tillage machine downtime during the season

If the tillage bearings are not customized and prepared for these kind of conditions, it can easily lead to damage and early life failure. This is especially if the seal fails or if a re-lubricated bearing is not regularly re-greased. Such events lower the productivity, increase maintenance costs and reduce overall profitability. It can also impact the precision and thus the quality of the farmer's work.

Typical conditions for independent disc applications

- Disc speed: 90–350 r/min
- Tractor speed: up to 20 km/h

SKF Agri Solutions – independent discs

Among the many products, especially developed to handle harsh conditions, for independent disc applications, SKF offers both bearings and complete hub units.

One of the most robust solutions is the SKF Agri Hub, consisting of angular contact ball bearings which are greased and sealed-for-life, a cassette seal, stub shaft for the arm interface and flange for the disc mounting. The integrated nature of the hub facilitates mounting and prolongs its service life to maximize the yield and the availability of agriculture machines.

Benefits SKF Agri Hub

OEMs

- Cost-effective solution
- Higher product quality and reliability
- Supports sustainability efforts
- Reduce assembly times

End users

- Increased farm productivity and profitability
- Relubrication-free
- Environmentally friendly
- Easy to install/replace



SKF Agri Hub for independent tillage discs

Conditions for seedbed finisher applications

- Two bearing units, one at each end of the finisher.
- Operates closely/directly in soil.
- Subject to high misalignment forces, statically due to imprecise mounting surfaces and dynamically due to the wide bearing span and attachment deflections.

SKF Agri Solutions – seedbed finishers

The bearing arrangements best suited to seedbed finisher applications are the SKF Flanged insert bearings. They come in a variety of designs with both square flanged units and oval flanged units. Common to all insert bearing solutions for agriculture applications though, is that they are relubrication-free with a five-lip seal¹⁾ to withstand the tough operating conditions.

Benefits insert bearing units

OEMs

- Differentiate designs
- Reduced warranty, engineering, testing and assembly costs

End users

- Extend service life 30 to 50% when fitted with five-lip seal¹⁾
- Increase farm productivity
- Reduce maintenance and ownership costs
- Reduce environmental impact

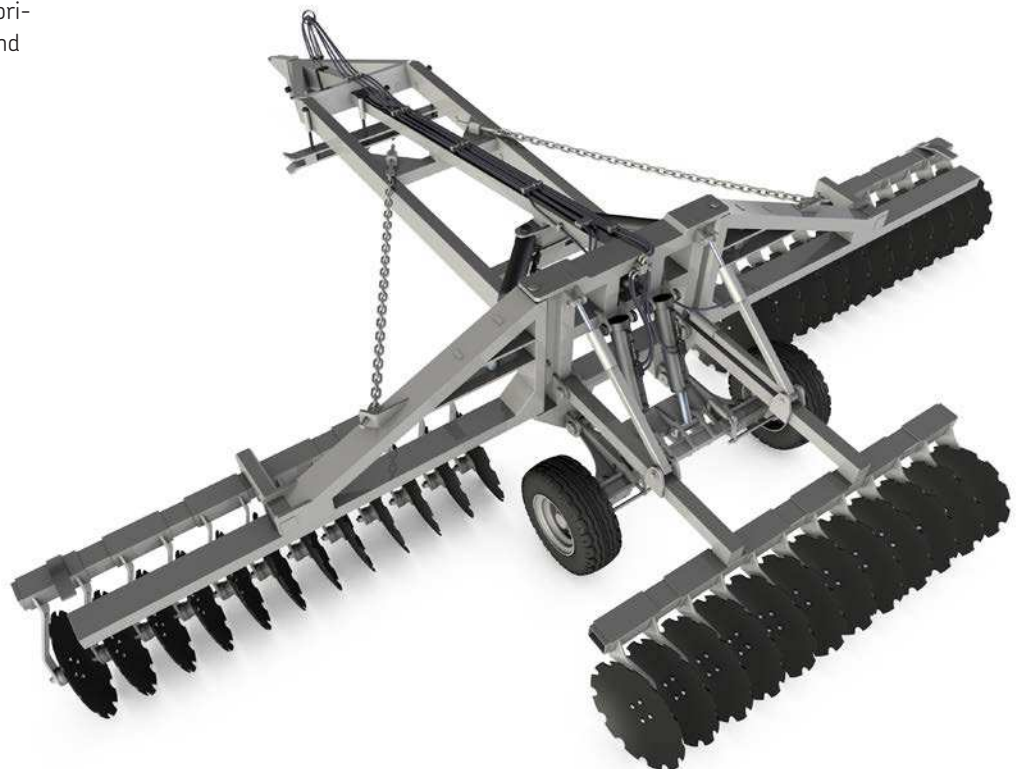

¹⁾ Based on SKF testing against conventional bearings. Savings and results will vary in specific applications

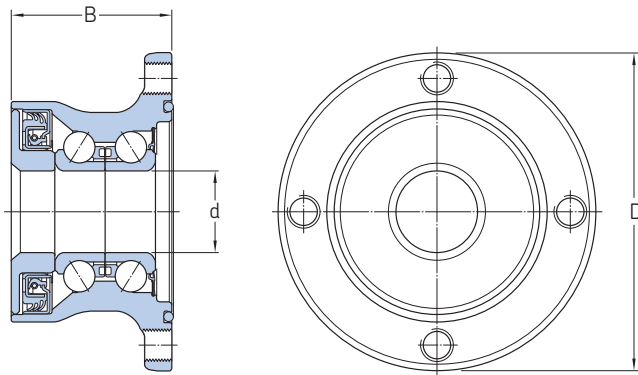

BAA-0003

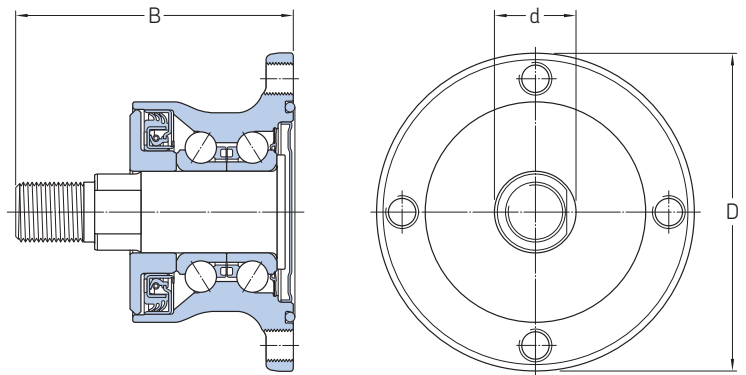

BAA-0004, BAA-0005, BAA-0013, BAA-0023

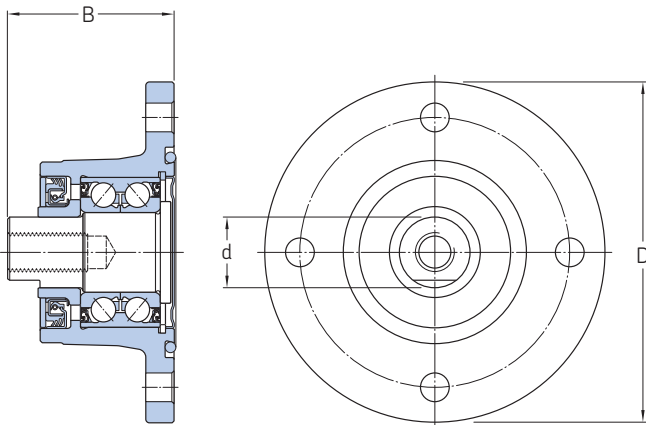

BAA-0026

Designation	Key dimensions			Flange mounting			Seal type
	D	d	Shaft thread	PCD	Number	Thread	
–	mm	–	mm	–	–	–	–

SKF Agri Hub – Independent disc

BAA-0003	–	30	No shaft	98	4	M12x1,25	Mudblock seal
BAA-0003 A	–	30	No shaft	98	4	M12x1,25	Mudblock seal
BAA-0004	–	30	M22x1,5	102	4	M12x1,25	Mudblock seal
BAA-0005	–	30	M24x1,5	102	4	M12x1,25	Mudblock seal
BAA-0006	–	30	M22x1,5	102	6	M12x1,25	Mudblock seal
BAA-0012	–	30	M22x1,5	102	5	M12x1,25	Mudblock seal
BAA-0013	–	30	M24x1,5	102	6	M12x1,25	Mudblock seal
BAA-0023	–	30	M22x1,5	102	4	M12x1,25	Mudblock seal
BAA-0026	–	39	female – M20 inch	82	4	M12x1.75 – inch	SKF Mudblock seal and cassette R safe seal
BAA-0037	–	39	female – M20 metric	82	4	M14x1,5 – metric	SKF Mudblock seal and cassette R safe seal

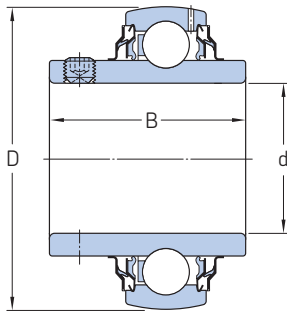

YAR-2RF

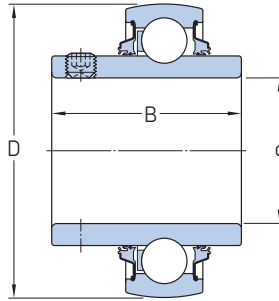

YARAG

Designation	Key dimensions			Seal type	Notes
	D	d	B		
-	mm			-	
Seedbed finisher					
YAR 207-2RF	72	35	42,9	2RF seal	
YAR 208	80	40	49,2	2RF seal	
YAR 209	85	45	49,2	2RF seal	
YAR 210	90	50	51,6	2RF seal	
YAR 211	100	55	55,6	2RF seal	
YAR 212	110	60	65,1	2RF seal	
YARAG 206	62	30	34,1	5 Lip	for harsh environments
YARAG 206-104	62	31,75	38,1	5-lip	for harsh environments
YARAG 207	72	35	42,9	5 Lip	for harsh environments
YARAG 208	80	40	49,2	5 Lip	for harsh environments
YARAG 209	85	45	49,2	5 Lip	for harsh environments
YARAG 210	90	50	51,6	5 Lip	for harsh environments
YAR 207-2F/AG	72	35	42,9	2F seal	optimized for Agri
YAR 208-2F/AG	80	40	49,2	2F seal	optimized for Agri
YAR 209-2F/AG	85	45	49,2	2F seal	optimized for Agri
YAR 210-2F/AG	90	50	51,6	2F seal	optimized for Agri
YAR 211-2F/AG	100	55	55,6	2F seal	optimized for Agri
YAR 212-2F/AG	110	60	65,1	2F seal	optimized for Agri

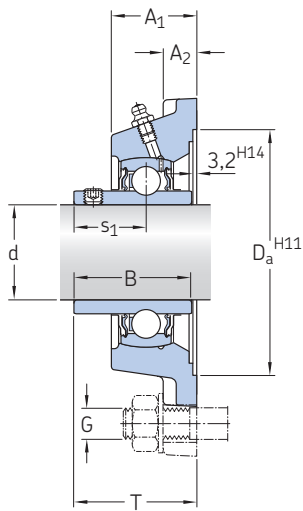

FY XX TF

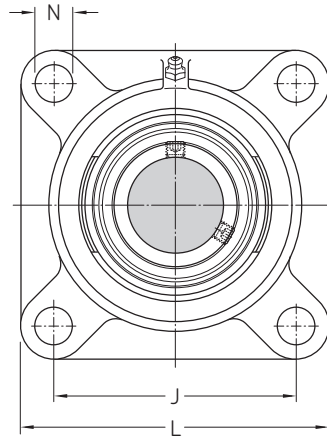

FY XX TR

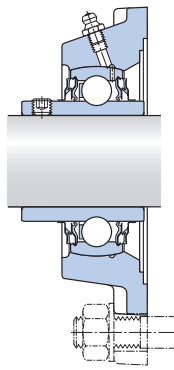

Designation	Key dimensions										Basic load ratings			Limiting speed
	A ₁	A ₂	B	D _A	J	L	N	G	s ₁	T	C	C ₀	P _u	
–	mm										N			r/min

Seedbed finishers – squared flanged insert bearing units

FY 35 TF	34,5	13	42,9	106,4	92	118	14	12	25,4	46,4	25 500	15 300	655	5 300
FY 40 TF	38,5	14	49,2	115,9	101,5	130	14	12	30,2	54,2	30 700	19 000	800	4 800
FY 45 TF	39	14	49,2	119,1	105	137	16	14	30,2	54,2	33 200	21 600	915	4 300
FY 50 TF	43	15	51,6	125,4	111	143	18	16	32,6	60,6	35 100	23 200	980	4 000
FY 50 TR	43	15	51,6	125,4	111	143	18	16	32,6	60,6	35 100	23 200	980	2 200
FY 60 TF	52	17	65,1	161,9	143	175	18	16	39,7	73,7	52 700	36 000	1 530	3 400

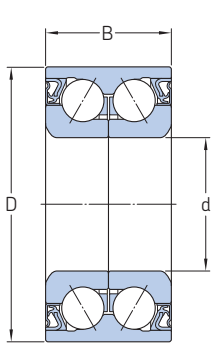

BAH

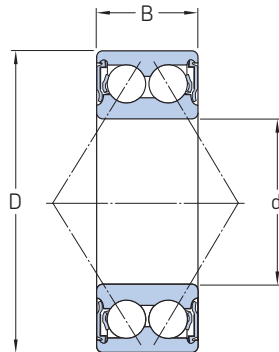

3307 2RS1

Designation	Key dimensions			Shaft thread	B	Seal type
	D	d				
–	mm	–	–	mm	–	

Independent disc – bearings

3307 CE-2RS1TN9	80	35	–	27	2RS1 seal
BAHB 636187 C	80	40	–	34	Cassette R safe seal
BTH-1024 AE	74	40	–	55	Taper bearing, cassette R safe seal

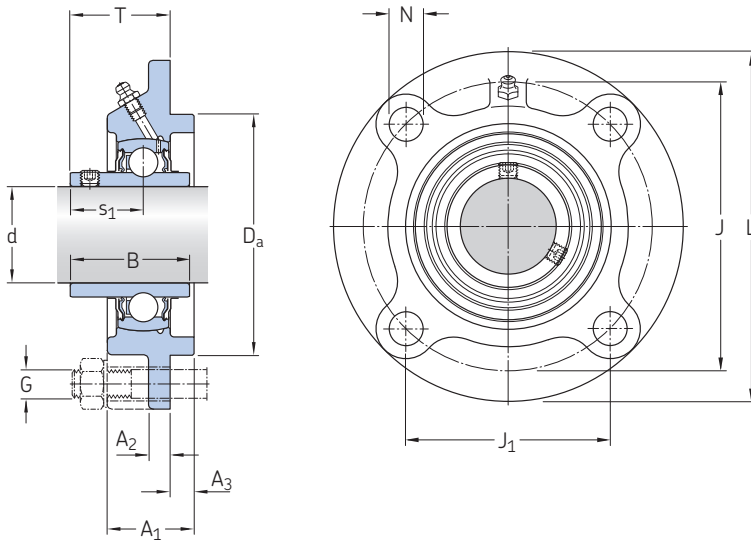

FYC XX TF

Designation	Key dimensions											Basic load ratings			Limiting speed
	A ₁	A ₂	A ₃	B	D _A	J	J ₁	L	N	G	s ₁	T	C	C ₀	
–	mm											N			r/min

Seedbed finishers – round flanged insert bearing units

FYC 40 TF	35,5	9	10	49,2	100	120	84,9	145	14	12	30,2	41,2	30 700	19 000	800	4 800
FYC 50 TF	39,5	14	12	51,6	110	138	97,6	165	16	14	32,6	42,6	35 100	23 200	980	4 000

Due to their weight, size and exposure to field conditions, most implements need to be lubricated once per day. Often, these lubrication points are spread out and situated underneath the equipment, making lubrication difficult.

Automatic lubrication is the most cost-effective solution for protecting this equipment. The system's metering device divides and proportions lubricant to the connected components.

Lubrication solutions for tillage

- HP-500W (See [page 44](#))
- HP-500-SSV (See [page 44](#))
- PF-VPBM (See [page 44](#))
- QLS 401 (See [page 45](#))
- P502 (See [page 46](#))
- P203 (See [page 46](#))
- KFA (See [page 47](#))
- KFG (See [page 47](#))
- SSV (See [page 48](#))
- SSVD (See [page 48](#))
- VPB (See [page 49](#))
- VPK (See [page 50](#))



Seeding

When the tillage process is complete it is time for seeding. Seeding briefly comprises the steps of opening a narrow furrow in the field for the seed, plant the seeds and then cover them by closing the furrow. These simple steps do though, require high precision. Loss of operational precision leads directly to a lower crop yield.

The challenge for a farmer when seeding is to do it quickly but accurately and at the lowest possible cost per hectare. This confirms the importance of selecting the right equipment, robust enough to avoid disc wobbling due to high loads, and properly sealed to resist ingress of dirt in order to achieve a long, reliable service life.

Typical seeding equipment applications:

- Opener discs
- Gauge wheels
- Closing discs
- Other positions: Press wheel, Implement wheel, Seedmeter drive shaft and Row markers.

Application challenges

The usage of seeding equipment is very intensive for a limited period of time and then followed by long periods of inactivity. The intense periods are signified by tough environmental conditions, and sustained work activity. This is in order to benefit from the growing conditions prepared during the tillage process. Because of the limited time available for optimal seeding, it is crucial to minimize the downtime during these periods.

Precision is yet again one of the most important factors and is directly connected to and dependent on the reliability of the bearings. The challenge is to maintain precise rotation no matter what the external conditions.

The consequences of a deficiency in precision, an incorrect seed placement, can lead to one or more of the following:

- Seeds are too close to one another: Insufficient nutrient per seed.
- Seeds are too far from one another: Lower utilisation of the field.
- Seed is too deep: Limited aeration and soil resists plant emergence.
- Seed is too shallow: Vulnerable to weather, temperature, animals and birds.

The net effect of the above, is a reduction in a farmer's yield of up to 60% per season.



Conditions for opener disc applications

When opening the furrow, the discs are forced into the soil:

- The bearing assemblies are exposed to mud, dust, crop residues and sometimes stones.
- Bearings and discs are subject to high loads

SKF Agri Solutions – opener discs

Within Agri Solutions, there is an Agri Hub product group specially designed for seeding applications and opener discs.

These are fully integrated units comprising a wide range of flexible designs and are compatible with discs that require external as well as internal mounting.

The Agri Hub intended for seeding applications, all feature a robust five-lip seal which implies that the unit is sealed for life and no re-lubrication is needed. Together with steel inserts, this ensures the bearings are well protected from solid contaminants such as mud, dust, fibers and also water. Through this heavy-duty sealing, the bearing's service life is increased and at the same

time, the need for maintenance and repairs is significantly reduced.

The integrated bearing is either a four-point contact single or double-row deep groove ball bearing depending on the capacity need. The flexibility of the design also allows to select a hub with a mounting flange made of metal-sheet for additional strength.

Benefits of the SKF Agri Hub

OEMs

- Cuts combined warranty, engineering, testing and assembly costs by up to 50%¹⁾
- Extends bearing unit service life
- Reduces mounting times and mistakes
- Differentiates designs
- Fast delivery worldwide

End-users

- Increases bearing unit service life by up to 40%¹⁾
- Reduces maintenance and ownership costs by up to 20%¹⁾
- Can be installed or replaced quickly and easily
- Improves profitability
- Fast delivery worldwide



¹⁾ All figures and graphs are rounded off and based on SKF testing against conventional bearings. Savings and results will vary in specific applications.

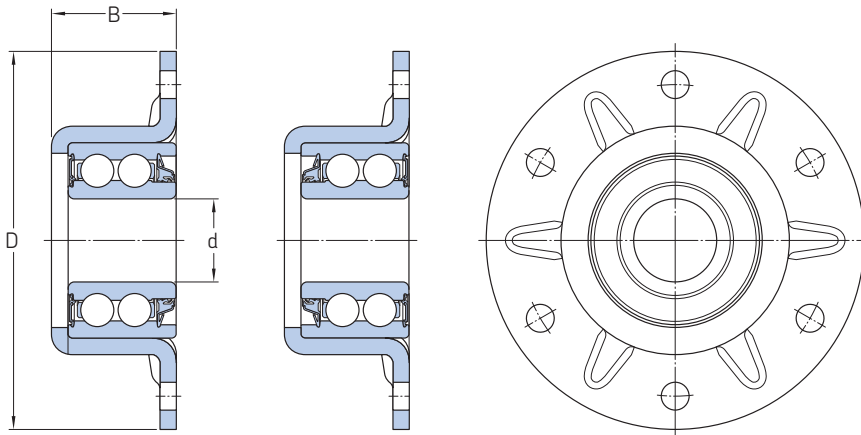

ADH-7545, ADH-7546

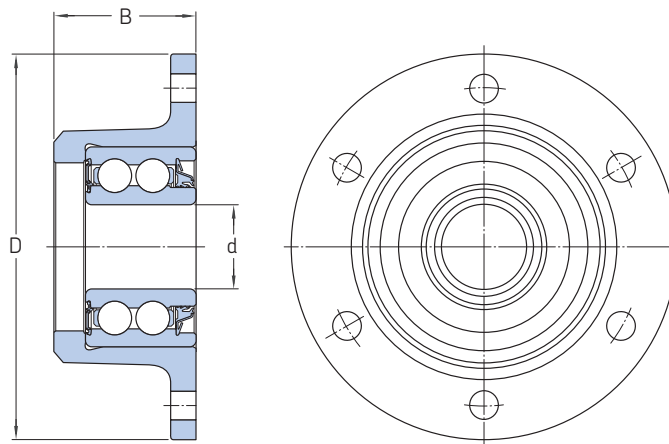

ADH-7558

Designation	Key dimensions		Flange mounting			Seal type
	d	B	PCD	Number	Thread	
-	mm		-		mm	-

Disc opener – external mounting – Agri Hub

ADH-7558	20	33,6	75	6	Ø6,7 +0,25/-0	Steel housing, 5-lip
ADH-7545	20	30,1	75	6	Ø6,7 +0,25/-0	Pressed steel housing, 5-lip on flange side
ADH-7545 B	16	30,1	75	6	Ø6,7 +0,25/-0	Pressed steel housing, 5-lip flange side
ADH-7546	20	30,1	75	6	Ø6,7 +0,25/-0	Pressed steel housing, 5-lip on opposite flange side
ADH-7546 B	16	30,1	75	6	Ø6,7 +0,25/-0	Pressed steel housing, 5-lip on opposite flange side

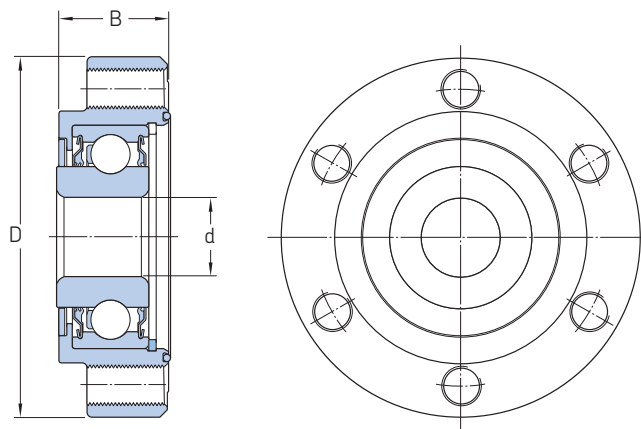

AGHU1660X6E-2L-V01

Designation	Key dimensions		Flange mounting			Seal type
	d	B	PCD	Number	Thread	
-	mm	-	-	-	mm	-

Disc opener – internal mounting – Agri Hub

AGHU1660X6E-2L-V01	16	22,7	60	6	M8X1,25	Zero wobble, 2 lip and labyrinth ring
--------------------	----	------	----	---	---------	---------------------------------------

Harvesting

Harvest season is hard, and a machinery breakdown at this crucial time can endanger a full season of hard work. Combine harvesters are amongst the most complex of farming machines; reliant on many sub-systems to achieve the harvesting, threshing and winnowing of the crop and final unloading of the grain.

Application challenges

After sitting idle for months, harvesters are put through gruelling, round-the-clock work schedules. If crop debris, dirt, detergent and water work their way into critical components, their service life is substantially reduced. Challenges include:

- Crop particle and other solid contaminant ingress
- Shock loads and stone impacts
- Wash-downs
- Task time criticality, machine availability

If the bearings and seals are not designed for these kind of conditions, it can easily lead to damage and early life failure. Such events lower productivity, significantly increase maintenance costs and reduce overall profitability.

SKF Agri Solutions benefits – combine harvesters

Among the many products especially developed to handle harsh conditions, SKF offers insert bearing units (maintenance free, quick and easy to mount), a range of radial ball and roller bearings, seals, actuators and lubrication systems.

For applications where the contamination risk is the highest, SKF agricultural insert bearing units with their relubrication-free design and increased service life, help to:

- Reduce maintenance and ownership costs
- Keep grease from contaminating the grain

SKF insert bearing units incorporate high performance sealing solutions that have been tested and proven under farm conditions. Appropriate to the precise application, the insert bearing range includes bearings, bearings and housings: both with bearing seals optimised for the application and the contamination level in that specific environment. The unitised nature of these designs means fewer separate components, allowing a plug and play approach for quick and easy mounting.

In the same mindset with high performance sealing and specific grease for harsh agricultural conditions, SKF has developed a

specific range of deep groove ball bearings for positions with limited space not allowing an SKF Y-bearing assembly or for the higher rotating speeds with tight press-fit on shaft and/or housing. This range is identified with an **AAG-VA387** suffix (e.g. **6206-2RS1/AAG-VA387**).

In the accompanying product tables, some solutions for the key components of combine harvesters are presented, covering header guidance and drive, feeder and beater shafts, augers and conveyors, as well as for threshing and chopping.

Other dimensions and products designs exist, please ask your SKF contact for your specific needs.



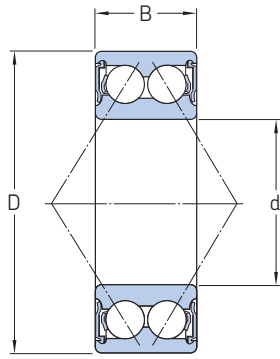

Double row angular contact ball bearing

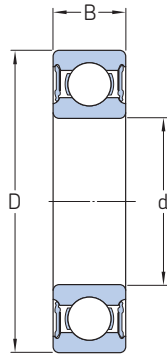

Deep groove ball bearing 2RS1

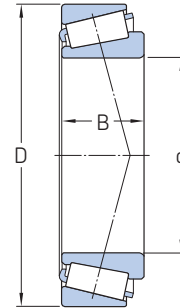

Tapered roller bearing

Designation	Key dimensions			Basic load rating		Speed ratings		Seal type
	D	d	B	C	C ₀	Reference	Limiting	
–	mm			kN		r/min		–
Header guiding – double row angular contact ball bearing								
3204 CE-2RS1TN9/C3	47	20	18	12,7	3,4	n/a	10 000	
3201 ATN9	32	12	15,9	10,1	5,6	20 000	22 000	
Header shaft – deep groove ball bearing								
6015-2RS1	115	75	20	41,6	33,5	–	3 400	
Header shaft – double row angular contact ball bearing								
3214 A	125	70	39,7	88,4	80	4 300	4 500	
Header gearbox – tapered roller bearing								
32010 X	80	50	20	60,5	88	6 000	8 000	
32012 X	95	60	46	163	245	4 300	6 700	
Header gearbox – deep groove ball bearing								
6013-2RS1	100	65	18	31,9	25	–	4 000	
6206-2RS1	62	30	16	16,5	11,2	–	7 000	
6305-2RS1	62	25	17	17,8	11,2	–	7 500	
6306-2RS1	72	30	19	22,9	15	–	6 300	
6307-2RS1	80	35	21	28,6	19	–	5 600	
6304-2RSH	52	20	15	16,8	7,8	–	9 500	

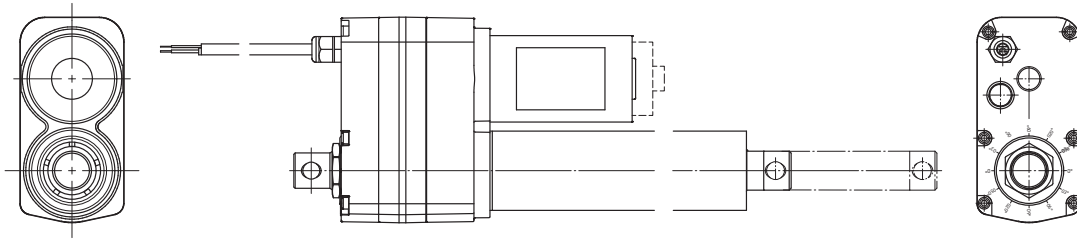

Example of designation	Load				Seal type
	Rated load push/pull	Holding force Max ¹⁾	Max speed	Max stroke	
–	N		mm/s	mm	–

Header attachment – reel in-out

CAHB-22-F4E-3050540-BB0LPT-000	10 000	20 000	13	450	Brake for holding force 20 000 N, Manual override, IP69K/66M with Gore automotive vent, environmental validation, Stroke self-limitation by built-in switches. Absolut position feedback.
--------------------------------	--------	--------	----	-----	---

Header attachment – locking, coupling and engagement

CAHB-21-F1E-0500267-BAA0PT-000	1 500	20 000	52,5	700	Brake for holding force 20 000 N, Manual override, IP69K/66M with Gore automotive vent, environmental validation. Absolut position feedback.
--------------------------------	-------	--------	------	-----	--

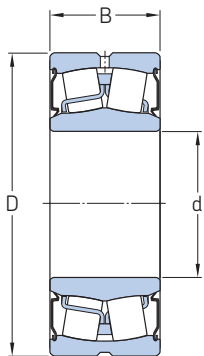

BS2-22XX-2RS/VT143

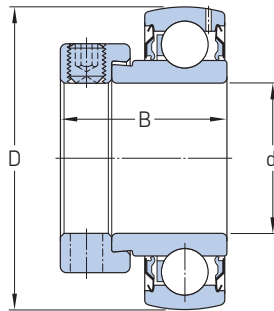

YET

Designation	Key dimensions			Basic load rating		Speed ratings		Seal type
	D	d	B	C	C ₀	Reference	Limiting	
–	mm			kN		r/min		–

Feeder shaft – sealed spherical roller bearing

BS2-2206-2RS/VT143	62	30	25	66,1	58,5	–	5 100
BS2-2207-RS/VT143	72	35	28	88,8	83	–	4 300
BS2-2208-2RS/VT143	80	40	28	98,5	91,5	–	3 900
BS2-2208-2RSW/GEM9	80	40	28	98,5	91,5	–	3 900

Feeder shaft – spherical roller bearing

22208 E	80	40	23	98,5	91,5	8 000	11 000
---------	----	----	----	------	------	-------	--------

Feeder PTO shaft - insert bearings

YET 208	80	40	43,2	30,7	19	–	4 800
---------	----	----	------	------	----	---	-------

¹⁾ The Holding force is also depending the stroke length

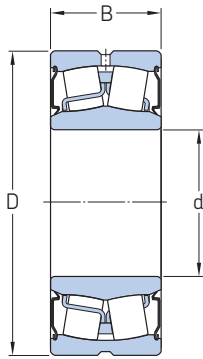

BS2-22XX-2RS/VT143

Designation	Key dimensions			Basic load rating		Speed ratings		Seal type
	D	d	B	C	C ₀	Reference	Limiting	
–	mm			kN		r/min		–

Beater shaft – sealed spherical roller bearing
BS2-2210-2RS/VT143

90	50	28	107	108	3 200
----	----	----	-----	-----	-------

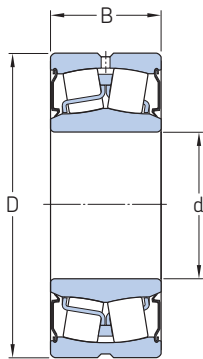

BS2-22XX-2RS/VT143

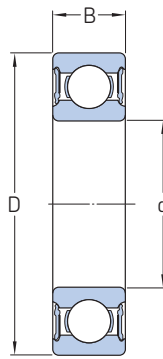

Deep groove ball bearing 2RS1

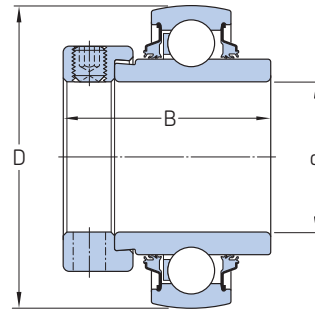

YELAG

Designation	Key dimensions			Basic load rating		Speed ratings		Seal type
	D	d	B	C	C ₀	Reference	Limiting	
–	mm			kN		r/min		–

Threshing rotary – sealed spherical roller bearing
BS2-2212-2RS/VT143

110	60	34	159	163	2 700
-----	----	----	-----	-----	-------

Threshing beater – deep groove ball bearing
6012-2RS1

95	60	18	30,7	23,2	4 300
----	----	----	------	------	-------

Threshing cleaning system – insert bearings
YELAG 209-112

85	44,45	56,3	33,2	21,6	850
----	-------	------	------	------	-----

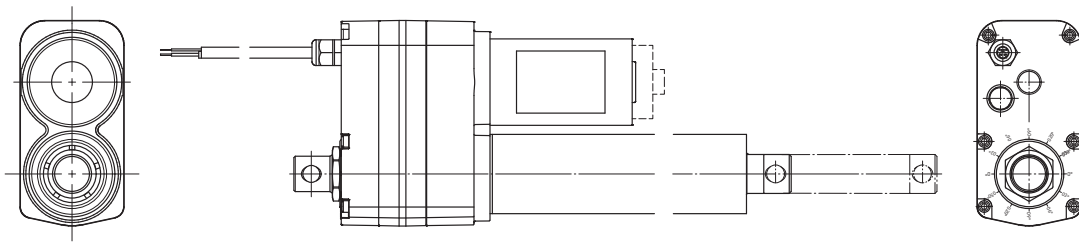

Example of designation	Load Rated load push/pull	Holding force Max ¹⁾	Max Speed	Max Stroke	Seal type
–	N		mm/s	mm	–
Threshing – concave adjustment – electro mechanical linear actuator					
CAHB-22-F4E-1300330-BBDLOT-000	10 000	20 000	13	450	Brake for holding force 20 000 N, manual override, IP69K/66M with gore automotive vent, environmental validation, stroke self-limitation by built-in switches. Absolut position feedback
Chaffer – chaffer adjustment – electro mechanical linear actuator					
CAHB-10-B5A-150315-ACCA0X-000	1 000	1 000	8	315	Compact, holding force over 1 000 N, IP66, environmental validation, stroke self-limitation by built-in switches.
Cleaning unit – chopper – electro mechanical linear actuator					
CAHB-21-F2E-8001052-BAAOPT-000	2 500	20 000	38	800	Brake for holding force 20 000 N, manual override, IP69K/66M with gore automotive vent, environmental validation. Absolut analog position output.
Cleaning unit – fan adjustment – electro mechanical linear actuator					
CAHB-21-F3E-1000326-BAALPT-000	4 500	20 000	22,5	600	Brake for holding force 20 000 N, manual override, IP69K/66M with gore automotive vent, environmental validation, stroke self-limitation by built-in switches. Absolut position feedback
Cleaning unit – sieve adjustment – electro mechanical linear actuator					
CAHB-10-B5A-150315-ACCA00-000	1 000	1 000	8	315	Compact, holding force over 1 000 N, IP66, environmental validation, stroke self-limitation by built-in switches
Grain – grain tank cover – electro mechanical linear actuator					
CAHB-22-F2E-6000864-BAAOPT-000	3 500	20 000	45	700	Brake for holding force 20 000 N, manual override, IP69K/66M with gore automotive vent, environmental validation. Absolut position feedback
Straw – chaff Spreader adjustment – electro mechanical linear actuator					
CAHB-10-A5A-250395-AAAAP0-000	1 000	1 000	8	315	Compact, holding force over 1 000 N, IP66, environmental validation, absolute position output, stroke self-limitation by built-in switches

¹⁾ The Holding force is also depending the stroke length

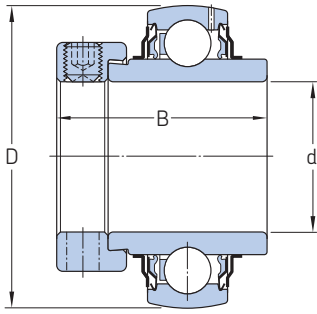

YEL-XXX-2F

Designation	Key dimensions			Basic load rating		Speed ratings		Seal type
	D	d	B	C	C ₀	Reference	Limiting	
–	mm			kN		r/min		–

Unloading Auger – insert bearing
YEL 207-106-2F

72 34,925 51,1 25,5 15,3 5 300

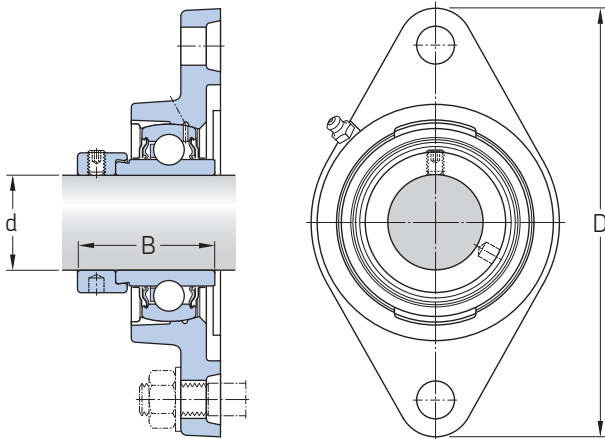

FYTBK XX WD

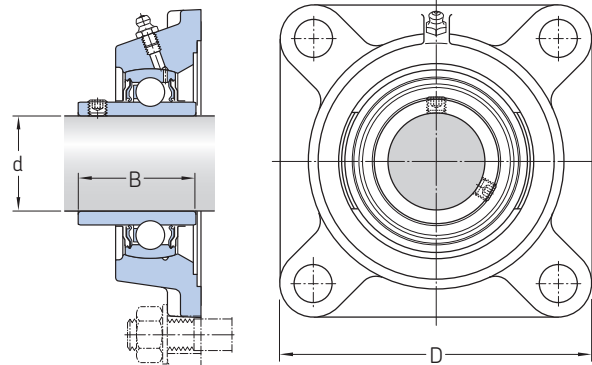

FY XX TF

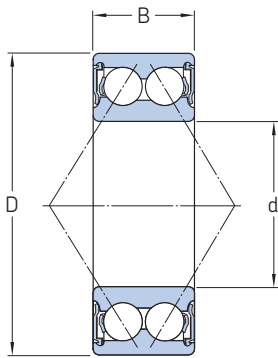

Double row angular contact ball bearing 2RS1

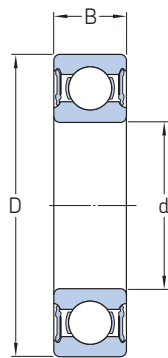

Deep groove ball bearing 2RS1

Designation	Key dimensions			Basic load rating		Speed ratings		Seal type
	D	d	B	C	C ₀	Reference	Limiting	
–	mm			kN		r/min		–

Conveyor – insert bearing

FYTBK 20 WD		20		12,7	6,55		1 800
FYTBK 25 WD		25		14	7,8		1 500
FYTBK 30 WD		30		19,5	11,2		1 200

Chopper – insert bearing

FY2.7/16	149,23	61,913	76,2	52,7	36		3 400
----------	--------	--------	------	------	----	--	-------

Sheave – deep groove ball bearing

6212-2RS1/HC5C3WT	110	60	22	55,3	36		4 000
-------------------	-----	----	----	------	----	--	-------

Sheave – double row angular contact ball bearing

3212 A-2RS1	110	60	36,5	73,5	58,5		4 000
-------------	-----	----	------	------	------	--	-------

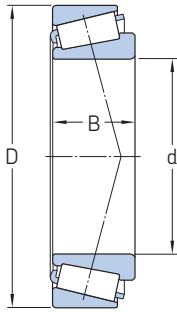

Tapered roller bearing

Designation	Key dimensions			Basic load rating		Speed ratings		Seal type
	D	d	B	C	C ₀	Reference	Limiting	
–	mm			kN		r/min		–

Wheel bearing – tapered roller bearing

33113/Q	110	65	34	142	208	4 300	5 600
32017/Q	130	85	29	140	224	3 400	4 800

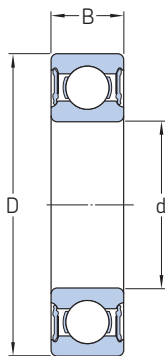

Deep groove ball bearing 2RS1

Designation	Key dimensions			Basic load rating		Speed ratings		Seal type
	D	d	B	C	C ₀	Reference	Limiting	
–	mm			kN		r/min		–

Fan drive – deep groove ball bearing

6218-2RS1	160	90	30	101	73,5	–	2 600
6020-2RS1	150	100	24	63,7	54	–	2 600

Engine cooling fan – deep groove ball bearing

6204-2RSH	47	20	14	13,5	6,55	–	10 000
6207-2RS1	72	35	17	27	15,3	–	6 300
6208-2RS1	80	40	18	32,5	19	–	5 600

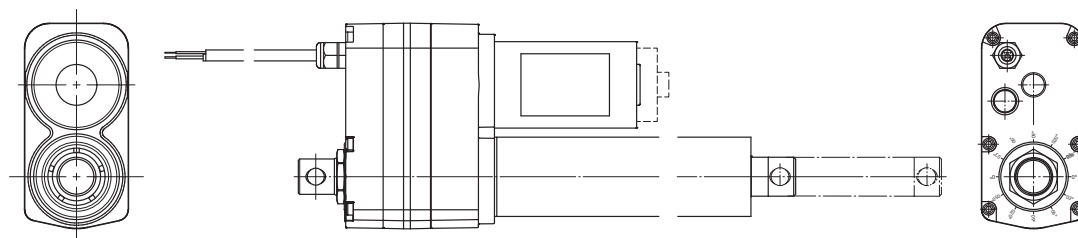

Example of designation	Load Rated load push/pull	Holding force Max ¹⁾	Max Speed	Max Stroke	Seal type
–	N		mm/s	mm	–
Folding unload adjustment – electro mechanical linear actuator					
CAHB-22-F3E-300529-BBAOPT-000	6 800	20 000	22	610	Brake for holding force 20 000 N, manual override, IP69K/66M with gore automotive vent, environmental validation, absolute position output
Spout adjustment – electro mechanical linear actuator					
CAHB-21-F3E-1000326-BAALPT-000	4 500	20 000	22,5	700	Brake for holding force 20 000 N, manual override, IP69K/66M with gore automotive vent, environmental validation, absolute position output, stroke self-limitation by built-in switches
Power Ladder adjustment – electro mechanical linear actuator					
CAHB-22-F3E-2600500-BBALOT-000	6 800	20 000	22	610	Brake for holding force 20 000 N, manual override, IP69K/66M with gore automotive vent, environmental validation, stroke self-limitation by built-in switches
Cabine tilt – electro mechanical linear actuator					
CAHB-22-F4E-3050540-BBOLPT-000	10 000	20 000	13	450	Brake for holding force 20 000 N, manual override, IP69K/66M with gore automotive vent, environmental validation, absolute position output, stroke self-limitation by built-in switches
Tailboard adjustment – electro mechanical linear actuator					
CAHB-10-A5A-250395-AAAAP0-000	1 000	1 000	8	315	Compact, holding force over 1 000 N, IP66, environmental validation, stroke self-limitation by built-in switches. Absolut position feedback

¹⁾ The Holding force is also depending the stroke length

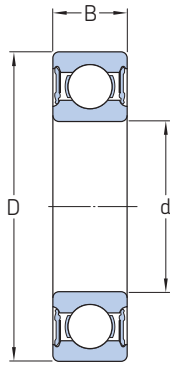

Deep groove ball bearing 2RS1

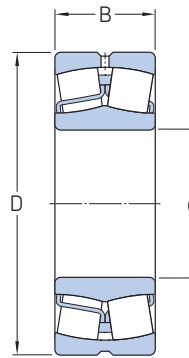

Spherical roller bearing

Designation	Key dimensions			Basic load rating		Speed ratings		Seal type
	D	d	B	C	C ₀	Reference	Limiting	
–	mm			kN		r/min		–
Duel speed main drive – deep groove ball bearing 6011-2RS1	90	55	18	29,6	21,2	–	4 500	
Triple gear pump drive – deep groove ball bearing 6205-2RSH	52	25	15	14,8	7,8	–	8 500	
Belt tensioner – deep groove ball bearing 6303-2RS1	47	17	14	14,3	6,55	–	11 000	
Tensioner and idler pulley – deep groove ball bearing 6208-2RS1/C3	80	40	18	32,5	19	–	5 600	
Crop processor (Harvester) – spherical roller bearing 22213 E/C3	120	65	31	198	208	5 000	7 000	
Blower (Harvester) – spherical roller bearing 22211 E	100	55	25	129	127	6 300	8 500	

Having your combine available and running at peak performance is critical during the harvest season. SKF ProFlex and Lincoln Quicklub automatic, progressive lubrication systems are well suited for these applications.

Lubrication solutions for harvesting

P203 (See [page 46](#))
 KFG (See [page 47](#))
 SSV (See [page 48](#))
 SSVD (See [page 48](#))
 VPB (See [page 47](#))
 VPB (See [page 49](#))
 VPK (See [page 50](#))



Baling

The process of converting windrows of crop into bales necessitates the gathering or pickup of crop, pressing and tying inside the bale chamber, ejection of the completed bale, and eventually wrapping of the bale. Much of this processing relies on rollers and for a square baler, a reciprocating plunger, so multiple bearings are required to produce an effective as well as a precise baling process.

Application challenges

Baling can impose heavy loads on the machine components, which is why it is essential that the bearings can sustain these stresses. It is also of great importance that at the same time, the bearings can exclude dust, dirt, straw and other contaminants to minimize time required for maintenance and service.

- Many bearings exposed to heavy loads
- Dust, dirt, straw and other contaminants
- Improving precision, and bale quality
- Increasing productivity

If the support bearings are not designed for these kind of conditions, it can easily lead to damage and early life failure. Such events lower productivity, increase maintenance costs and reduce overall profitability.

SKF SKF Agri Solutions benefits – balers

Among the many products especially developed to handle harsh conditions, SKF offers its insert bearings (maintenance free, quick and easy to mount), a range of radial ball and roller bearings, and seals.

For applications where the contamination risk is the highest, SKF agricultural insert bearing units with their relubrication-free design and increased service life, help to:

- Reduce maintenance and ownership costs
- Keep grease from contaminating crops, soil, or groundwater supplies

SKF robust, compact and integrated sensor bearing solutions allow the counting of shaft rotations or measurement of shaft speed, reliably and precisely, despite the harsh environment. This helps to:

- Improve machine output, process precision and farming productivity
- Prevent machine, early life failures

In the accompanying product tables, solutions for the key components of both round and square balers are presented, covering twine tensioning, wrapping, plunger drive and plunger rod bearings.



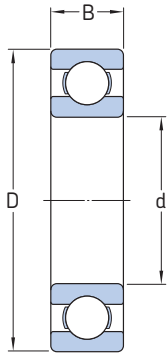

Designation	Key dimensions			Basic load rating		Speed ratings		Seal type
	D	d	B	C	C ₀	Reference	Limiting	
–	mm			kN		r/min		–

Round baler – twine tensioner – insert bearing

BBY-0076	31,5	6,35	12	3,25	1,37	–		
BBY-0083	31,5	6,35	16	3,25	1,37	–		

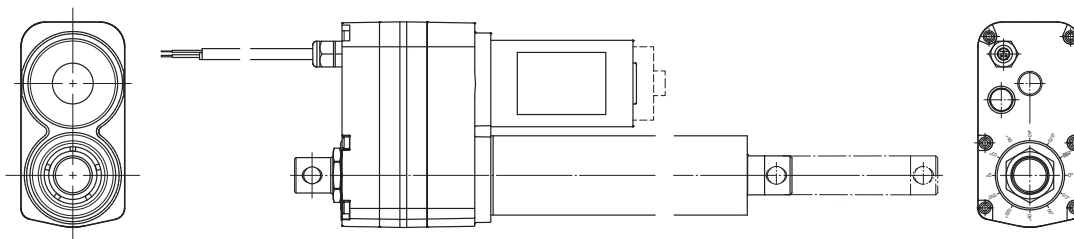

Example of designation	Load Rated load push/pull	Holding force Max ¹	Max Speed	Max Stroke	Seal type
–	N		mm/s	mm	–

Net/Twine wrapping and cutting – electro mechanical linear actuator

CAHB-22-F2E-2000429-BAAOPT-000	3 500	20 000	45	700	Brake for holding force 20 000 N, manual override, IP69K/66M with gore automotive vent, environmental validation, absolute position output
--------------------------------	-------	--------	----	-----	--

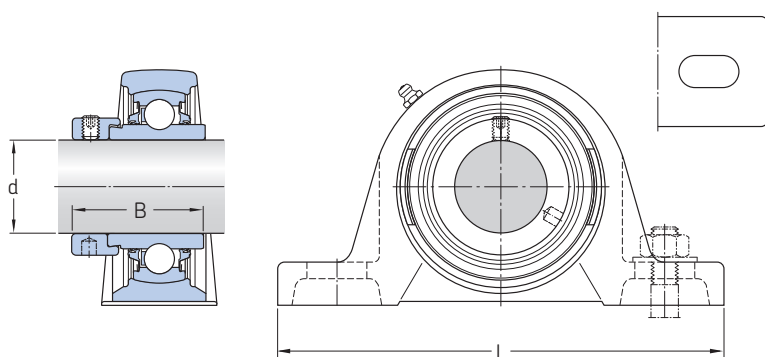

SY 50 WDW

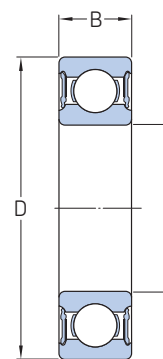

Deep groove ball bearing 2RS1

Designation	Key dimensions			Basic load rating		Speed ratings		Seal type
	D	d	B	C	C ₀	Reference	Limiting	
–	mm			kN		r/min		–

Roll – insert bearing
SY 50 WDW

90	50	62,7	35,1	23,2	800
----	----	------	------	------	-----

Roll – deep groove ball bearing
6307-2RS1

80	35	21	35,1	19	6 000
----	----	----	------	----	-------

¹) The Holding force is also depending the stroke length

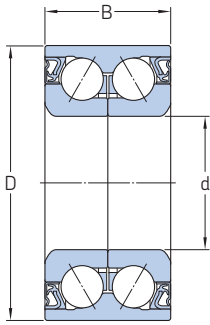

BAH

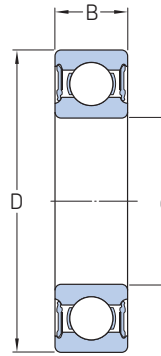

Deep groove ball bearing 2RS1

Designation	Key dimensions			Basic load rating		Speed ratings		Seal type
	D	d	B	C	C ₀	Reference	Limiting	
–	mm			kN		r/min		–

Rotor drive – hub bearing unit
BAH-0069

Serpentine arm – deep groove ball bearing
6211-2RS1/C3

100	55	21	46,2	29	4 300
-----	----	----	------	----	-------

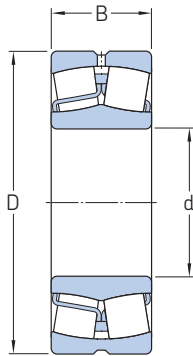

Spherical roller bearing

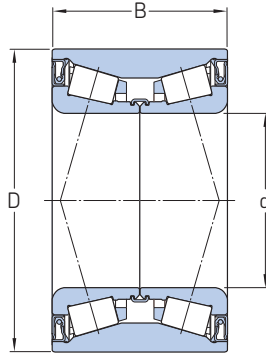

Double row tapered roller bearing

Designation	Key dimensions			Basic load rating		Speed ratings		Seal type
	D	d	B	C	C ₀	Reference	Limiting	
–	mm			kN		r/min		–

Square baler – plunger roller – thrust roller bearing
BTHB-1866046AC-Q

68	41	40	80.9	118
----	----	----	------	-----

Square baler – plunger rod – spherical roller bearing
23220 CC/W33

180	100	60.3	498	600	2 400	3 400
-----	-----	------	-----	-----	-------	-------

Square baler – plunger conrod bearing – spherical roller bearing
22213 E

120	65	31	198	208	5 000	7 000
-----	----	----	-----	-----	-------	-------

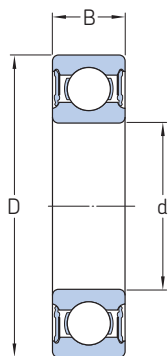

Deep groove ball bearing 2RS1

Designation	Key dimensions			Basic load rating		Speed ratings		Seal type
	D	d	B	C	C ₀	Reference	Limiting	
–	mm			kN		r/min		–

Flywheel – deep groove ball bearing

6213-2RS1	120	65	23	58,5	40,5	3 600	
6209-2RS1	85	45	19	28,1	20,4	5 000	

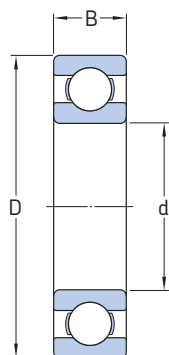

Deep groove ball bearing

Designation	Key dimensions			Basic load rating		Speed ratings		Seal type
	D	d	B	C	C ₀	Reference	Limiting	
–	mm			kN		r/min		–

Clutch – deep groove ball bearing

61844	270	220	24	78	110	4 500	2 800
-------	-----	-----	----	----	-----	-------	-------

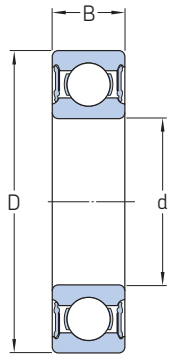

Deep groove ball bearing 2RS1

Designation	Key dimensions			Basic load rating		Speed ratings		Seal type
	D	d	B	C	C ₀	Reference	Limiting	
–	mm			kN		r/min		–
Sprocket – deep groove ball bearing 6204-2RS1/C3	47	20	14	10,8	6,55		10 000	
Baler nose roll – deep groove ball bearing 6211-2RS1	100	55	21	46,2	29		4 300	

Baling hay is similar to harvesting crops where uptime and availability are important. Manual lubrication can take more than an hour on these machines, which equates to 35 bales of hay production. Get back that hour each day with SKF and Lincoln automatic lubrication systems. Component failures and resulting downtime are reduced significantly, and dirty, greasy manual lubrication is eliminated. All the operator needs to do is check the reservoir. Progressive as well as single-line lubrication systems cover the numerous body points and the knotter. Both lubrication systems can be used to lubricate the chains and drives with brushes or nozzles. Precise, metered quantities of lubricant reduces wear and helps to increase smooth machine operation. Mechanically operated pumps that can be driven easily by the existing baler drive shaft are in the portfolio as well.

Lubrication solutions for baling

HP-500W (See [page 44](#))
 HP-500-SSV (See [page 44](#))
 PF-VPBM (See [page 44](#))
 QLS 401 (See [page 45](#))
 P502 (See [page 46](#))
 P203 (See [page 46](#))
 KFA (See [page 47](#))
 KFG (See [page 47](#))
 SSV (See [page 48](#))
 SSVD (See [page 48](#))
 VPB (See [page 49](#))
 VPK (See [page 50](#))
 VPM (See [page 51](#))
 SP/EY28 (See [page 51](#))
 KFB (See [page 50](#))
 EOP2-12 (See [page 51](#))
 MOP212 / MGP101 (See [page 52](#))



Attachment and trailer wheels

Implement wheel and walking beam of tillage and seeding machines

Aside from the tillage or seeding discs themselves, multiple bearings are used to mount implement wheels and to provide walking beam support structures.

SKF Agri Solutions – tapered roller bearings

For implement wheel and walking beam support, SKF offers a range of single row tapered roller bearings. In these applications, the bearings are used in opposing pairs and are designed to accommodate combined loads (simultaneous radial and axial).

Application challenges

Implements and attachments come in a variety of shapes and sizes, but what they have in common is that the associated bearings must tolerate the harsh working environment. Some of the challenges faced, include:

- Combined radial and axial loads
- Shock loading
- Higher machine speeds (for higher productivity)

If the support bearings are not designed for these kind of conditions, it can easily lead to damage and early life failure. Such events lower productivity, increase maintenance costs and reduce overall profitability.

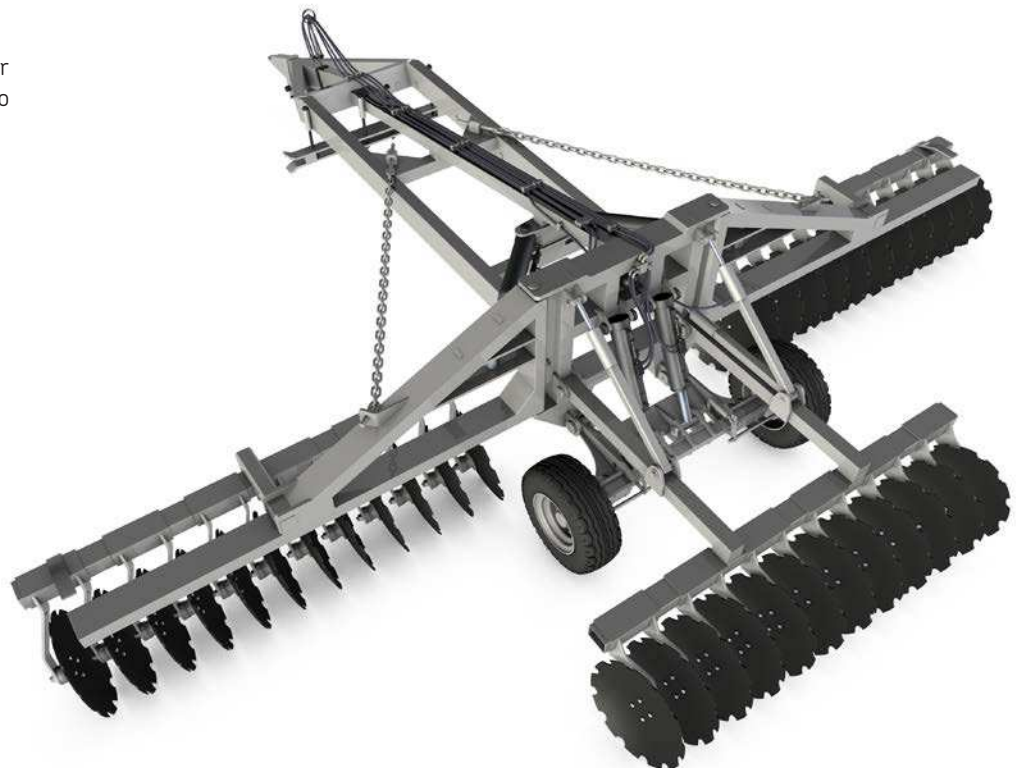

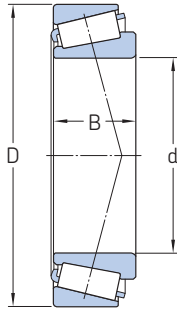

Tapered roller bearing

Designation	Key dimensions			Basic load rating		Speed ratings		Seal type
	D	d	B	C	C ₀	Reference	Limiting	
–	mm			kN		r/min		–

Implement wheel and walking beam – tapered roller bearing

JLM 104948 AA/910 AA	82	50	21,5	88,9	110	6 300	8 000
LM 102949/910	73,431	45,242	19,558	66	75	7 000	8 500
LM 11949/910	45,237	19,05	15,494	33,8	27,5	13 000	16 000
LM 12749/710	45,237	22	15,494	33,9	31	12 000	15 000
LM 29749/710	65,088	38,1	18,034	53	57	8 000	10 000
LM 48548/510	65,088	34,925	18,034	58	57	8 500	10 000
LM 501349/310	73,431	41,275	19,558	67,6	68	7 500	9 000
LM 503349/310	75	46	18	62,1	71	7 000	8 500
LM 67048/010	59,131	31,75	15,875	42,8	41,5	9 500	11 000
LM 48548/510	65,088	34,925	18,034	58	57	8 500	10 000

Agricultural attachments endure direct exposure to the harshest operating conditions on any farm. SKF and Lincoln automatic or centralized lubrication systems help to increase equipment service life with minimal maintenance effort.

Lubrication solutions for attachment and trailer wheels

- HP-500W (See page 44)
- HP-500-SSV (See page 44)
- PF-VPBM (See page 44)
- QLS 401 (See page 45)
- P502 (See page 46)
- P203 (See page 46)
- KFA (See page 47)
- KFG (See page 47)
- SSV (See page 48)
- SSVD (See page 48)
- VPB (See page 49)
- VPK (See page 50)
- VPM (See page 51)



Lubrication solutions

Lincoln HP-500 W / HP-500 W-SSV

Manually operated single-stroke piston pump

Features and benefits:

- Uses standard cartridges
- No electrical power supply necessary
- Refillable bulk reservoir
- Easy to use
- Available with or without integrated metering device



Function principle: manually operated single-stroke piston pump
 Lubricant: grease up to NLGI 2
 Operating temperature: -25 to +70 °C (-13 to +158 °F)

Number of lubricant outlets:

HP-500W 1
 HP-500W-SSV 6, 8, 10, 12

Metering quantity per stroke

HP-500W 1,5 cm³ (0.09 in³)
 HP-500W-SSV 0,2 cm³/SSV-outlet, 0.012 in³/SSV-outlet

Capacity of the reservoir

with cartridge 0,4 l (0.11 gal)
 without cartridge 0,5 l (0.13 gal)
 Connection main line M 10 × 1

Operating pressure

HP-500W 400 bar 5 800 psi
 HP-500W-SSV 350 bar 3 625 psi

Dimensions

HP-500W 95 × 165 × 380 mm 3.74 × 6.50 × 14.96 in
 HP-500W-SSV 95 × 165 × 405 mm 3.74 × 6.50 × 15.94 in

Mounting position upright

SKF PF-VPBM

Manually operated piston pump

Features and benefits:

- Reliable, user-friendly pump
- Utilizes grease cartridges for convenience
- Varying number of outlets available



Function principle manually operated piston pump
 Lubricant grease up to NLGI 2
 Operating temperature -25 to +80 °C (-13 to +176 °F)
 Number of lubricant outlets 1-12

Metering quantity per stroke

without metering device 2 cm³ (0.12 in³)
 with metering device 0,2 cm³/outlet (0.012 in³/outlet)
 Capacity of cartridge 450 cm³/ 400 g (27.46 in³/0.88 lbs)
 Connection main line M 10 × 1
 Operating pressure 400 bar (5 800 psi)

Dimensions

min 140 × 156 × 396 mm 5.51 × 6.14 × 15.59 in
 max 140 × 156 × 506 mm 5.51 × 6.14 × 19.92 in
 Mounting position any

QLS 401 SSV / QLS 401 SSVD

Electric pump unit with follower plate and integrated metering device

Features and benefits:

- Back- or bottom-mounted progressive metering devices
- Internal lubricant return possible
- Integrated pressure-relief valve
- External programming via keypad
- System monitoring with display of faults
- Stirring paddle



Function principle	Electrically operated piston pump with stirring paddle
Lubricant grease:	NLGI 2
fluid grease:	NLGI 00, 000
Number of lubricant outlets	up to 18
Metering quantity	1,0 cm ³ /min (0.06 in ³ /min)
Capacity of the reservoir	1 and 2 l (0.26 and 0.53 gal)

Connection main line

via SSV:	see information for SSV or SSVD
via connection block:	G 1/8
Operating voltage	12/24 V DC
	120 and 230 V AC (± 10%)
Operating pressure	205 bar (2 975 psi)
Operating temperature	-25 to +70 °C (-13 to +158 °F)
Protection class	IP 6K9K, NEMA 4

Dimensions

min	237 × 215 × 230 mm	9.33 × 8.46 × 9.05 inch
max	237 × 235 × 353 mm	9.33 × 9.25 × 13.89 inch
Mounting position	upright	

P502

Electrically operated piston pump

Features and benefits:

- Economical operation
- Fits in tight/small places
- Flexible design for 12 and 24 V DC voltage supply
- Optional pressure-release valve
- Optimised housing design for splash zones in food processing



Function principle	Electrically operated piston pump
Lubricant grease:	up to NLGI 2
Number of lubricant outlets	1-2
Metering quantity per pump element	1,0; 1,2; 1,8; 2,4 cm ³ /min (0.06; 0.07; 0.11; 0.15 in ³ /min)
Capacity of the reservoir	1 l (0.26 gal)
Connection main line	G 1/4
Operating voltage	12/24 V DC
Protection class	IP6K9K, IP65, IP67 depending on type of electrical connection
Operating pressure	270 bar (3 915 psi)
Operating temperature	-25 to +70 °C (-13 to +158 °F)
Dimensions	250 × 150 × 270 mm 9.84 × 5.91 × 10.63 in
Mounting position	any with follower plate upright without follower plate

P203

Electrically operated piston pump

Features and benefits:

- Optional control printed circuit boards with different operating settings
- Range of reservoir types offered
- For DC or AC applications
- Variety of pumping elements for different output available



Function principle	Electrically operated piston pump
Lubricant grease:	up to NLGI 2
oil:	with min. 40 mm ² /s
Number of lubricant outlets	up to 3 pump elements
Metering quantity per pump element	
K5, B2	2 cm ³ /min (0.12 in ³ /min)
K6	2,8 cm ³ /min (0.17 in ³ /min)
K7, C7	4 cm ³ /min (0.24 in ³ /min)
KR adjustable	0,7-3,0 cm ³ /min (0.042-0.18 in ³ /min)
Capacity of the reservoir	2; 4; 8; 15 l (0.53, 1.05, 2.11, 3.96 gal)
Connection main line	G 1/4
Operating voltage	12/24 V DC 100-260 V AC, 50/60 Hz
Operating pressure	350 bar (5 075 psi)
Operating temperature	
V DC version	-40 to +70 °C (-40 to +158 °F)
V AC version	-25 to +70 °C (-13 to +158 °F)
Dimensions	
min	211 × 224 × 287 mm 8.31 × 8.82 × 11.29 inch
max	211 × 250 × 774 mm 8.31 × 9.84 × 30.47 inch
Mounting position	any with follower plate upright without follower plate

KFA

Electrically operated piston pump

Features and benefits:

- Integrated control system provides:
 - Non-volatile memory with PIN-code protection
 - Storage of residual interval, lubricating cycle and faults signals
 - Saved data in event of a power failure
 - Connection for external pushbutton and inductive cycle switch
 - Interval and contact times can be set independently
- Fits in tight/small places

Function principle	Electrically operated piston pump
Lubricant grease:	up to NLGI 2
Number of lubricant outlets	1-2
Metering quantity	1,0; 1,5; 2,0 cm ³ /min (0.061; 0.092; 0.122 in ³ /min)
Capacity of the reservoir	1 l (0.26 gal)
Connection main line	M 14 × 1.5
Operating voltage	12 and 24 V DC; 115 and 230 V AC; (± 10%)
Operating pressure	300 bar (4 350 psi)
Operating temperature	–25 to +75 °C (–13 to +167 °F)
Protection class	IP6K9K
Dimensions	216 × 150 × 234,5 mm 8.1 × 5.9 × 9.2 inch
Mounting position	upright



KFG

Electric pump unit for progressive lubrication systems

Features and benefits:

- Durable and reliable components designed for extreme conditions (with positively driven pump elements)
- Versatile: can be used with single-line and progressive systems
- Safe: through fill-level monitoring, lubrication system monitoring, pressure relief and control unit
- Pin code protection of control unit available
- Options: Top filling, several electronic options, can bus

Function principle	Electrically operated piston pump
Lubricant grease:	up to NLGI 2 compatible with plastics, NBR elastomers, copper and copper alloys
Number of lubricant outlets	up to 3
Metering quantity per pump element	0,8; 1,3; 1,8; 2,5; 5,0 cm ³ /min (0.049, 0.079, 0.11, 0.15, 0.31 in ³ /min)
Capacity of the reservoir	2; 4; 6; 8; 10; 12; 15; 20 kg (4.4; 8.8; 13.2; 17.6; 22; 26.5; 33; 44 lbs)
Connection main line	M 14 × 1,5 female thread
Operating voltage	12 V DC, 24 V DC, 230 (90-264) V AC; (± 10%)
Operating pressure	200-300 bar (2 900-4 350 psi)
Operating temperature with spring-return pump element	–25 to +70 °C (–13 to +158 °F)



SSV

Progressive metering devices in block design

Features and benefits:

- Sizes up to 22 outlets
- High operating pressure
- Available in different materials
- Exact lubricant metering
- Unique internal crossporting technology
- Optionally equipped with visual monitoring pin or with electrically monitored piston detector



Function principle

Outlets
Lubricant

Metering quantity per stroke and outlet
Operating temperature
Operating pressure
Materials

Connection inlet
Outlet connection

Dimensions

min
max

metering devices

6-22
Grease up to NLGI 2
oil at least 40 mm²/s

0,2 cm³ (0.01 in³)
-40 to +200 °C (-40 to +390 °F)
max. 400 bar (5 800 psi)

black chromated steel
stainless steel

G 1/8 or 1/8 NPTF
M 10 × 1

60 x 60 x 30 mm 2.36 x 2.36 x 1.18 in
180 x 60 x 30 mm 7.08 x 2.36 x 1.18 in

SSVD

Progressive metering devices in block design

Features and benefits:

- Ten different metering screw sizes available
- Optionally visual or electrical monitoring
- Nickel plated surface treatment for corrosive environment available
- Ideal for use as primary metering device



Function principle

Outlets
Lubricant

Metering quantity per cycle and outlet
Operating temperature
Operating pressure
Materials

Connection inlet
Outlet connection

Dimensions

min
max

metering devices

6-22
Grease up to NLGI 2
oil at least 40 mm²/s

min. 0,08 cm³ (0.001 in³)
max. 1,80 cm³ (max. 0.110 in³)
-25 to +70 °C (-13 to +158 °F)

max. 350 bar (5 075 psi)
black chromated steel or nickel plated

G 1/8 or 1/8 NPTF
M 10 × 1

70 x 60 x 40 mm 2.75 x 2.36 x 1.57 in
190 x 60 x 40 mm 7.84 x 2.36 x 1.57 in

VPB

Progressive metering devices in block design

Features and benefits:

- Robust and cost-efficient
- Available in metric and inch design
- Optional visual or electric monitoring
- Internal crossporting possibility, use of standard tube fittings
- Variety of material as zinc coated or stainless steel available



Function principle	metering devices
Outlets	6-20
Lubricant	grease up to NLGI 2 oil with min. viscosity of 12 mm ² /s
Metering quantity per outlet	0,2 cm ³ /stroke (0.01 in ³ /stroke)
Operating temperature	-25 to +110 °C (-13 to +230 °F)

Operating pressure max.

Oil	200 bar (2 900 psi)
Grease	300 bar (4 350 psi)
Material	stainless steel, tinned/nitrile

Connection inlet / outlet

VPBM	M 10 × 1
VPBG	G 1/8

Dimensions

min.	60 × 60 × 30 mm 2.36 × 2.36 × 1.18 in
max.	165 × 60 × 30 mm 6.48 × 2.36 × 1.18 in

Mounting position on machines

without vibration	any
with vibration	piston position should be 90° to machine movements direction

VPK

Sectional lubricant metering devices

Features and benefits:

- Volumetric flow of up to 0,05 cm³/min
- Universal use in continuous or intermittent operation
- Metering sections with variable metering amount
- Internal consolidation of outlets
- Visual or electrical monitoring optional
- Safe sealing concept with porting plates



Function principle	metering devices	
Outlets	6-20	
Lubricant	grease up to NLGI 2 oil with min. viscosity of 12 mm ² /s	
Metering quantity per outlet	0,1-1,2 cm ³ /stroke (0.006-0.073 in ³ /stroke)	
Operating temperature	-25 to +90 °C (-13 to +194 °F)	
Operating pressure max.		
oil	200 bar (2 900 psi)	
grease	300 bar (4 350 psi)	
Material		
Inlet, separator, end plate	steel, galvanized/NBR	
sections/piston plates	steel, galvanized	
Connection inlet		
VPM	M 14 × 1,5	
VPG	G 1/4	
Connection outlet		
VPM	M 10 × 1	
VPG	G 1/8	
Dimensions		
min.	98 × 82,5 × 41 mm	3.86 × 3.25 × 161 in
max.	238 × 82,5 × 41 mm	9.37 × 3.25 × 161 in
Mounting position on machines		
without vibration	any	
with vibration	piston position should be 90° to machine movements direction	

VPM

Sectional lubricant metering devices for progressive automatic lubrication systems

Features and benefits:

- Volumetric flow of up to 1 000 cm³/min (61 in³/min)
- Universal use in continuous or intermittent operation
- Metering sections with variable metering amount
- Internal and external consolidation of outlets
- Visual or electrical monitoring optional
- Ideal as main metering device
- All outlets with build-in non-return valves



Function principle	metering devices	
Outlets	6-20	
Lubricant	grease up to NLGI 2 oil with min. viscosity of 12 mm ² /s	
Metering quantity per outlet	0,1-1,2 cm ³ /stroke (0.006-0.073 in ³ /stroke)	
Operating temperature	-25 to +90 °C (-13 to +194 °F)	
Operating pressure max.		
Oil	200 bar (2 900 psi)	
Grease	300 bar (4 350 psi)	
Material		
Inlet, separator, end plate sections/piston plates	steel, galvanized/NBR steel, galvanized	
Connection inlet		
VPM	M 14 × 1,5	
VPG	G 1/4	
Connection outlet		
VPM	M 10 × 1	
VPG	G 1/8	
Dimensions		
min.	98 × 82,5 × 41 mm	3.86 × 3.25 × 161 in
max.	238 × 82,5 × 41 mm	9.37 × 3.25 × 161 in
Mounting position on machines		
without vibration	any	
with vibration	piston position should be 90° to machine movements direction	

SP/EY28

Hydraulically operated piston pump unit for SKF MultiFlex multi-line centralized lubrication systems

Technical features:

- Lubricant: mineral, synthetic and environmental compatible oils
- Operating viscosity: 20 - 1 500 mm²/s
- Reservoir capacities: 1,0 l
- Number of outlets: 1 - 9
- Displacement: 4,5; 6 or 7 cm³/stroke
- Pressure: 60 to max. 200 bar



KFB

Electrically operated gear pump

Features and benefits:

- Compact pump unit
- Integrated pressure-relief valve and pressure-regulating valve
- Visual or optional electrical fill-level monitoring
- Optional integrated control
- Optional pre-assembled metering device of VN series



Function principle	Electrically operated gear pump
Lubricant	fluid grease of NLGI 000 or 00
Number of lubricant outlets	1
Metering quantity	50 cm ³ /min (3.05 in ³ /min)
Operating temperature	-25 to +75 °C (-13 to +167 °F)
Operating pressure	max. 38 bar (550 psi)

Capacity of the reservoir

KFB(S)1-W	1 l (0.26 gal)
KFB(S)1	1,4 l (0.37 gal)
Material (reservoir)	translucent plastic
Connection outlet	ø 10 × 1.5
Voltage	12 / 24 V DC
Current	3,8 A / 1,7 A
Rated output	46 W / 41 W
Protection class	IP 6K6K / IP 6K9K

Dimensions depending on model

KFB(S)1	216 × 150 × 235 mm	8.5 × 5.9 × 9.3 in
KFB(S)1-W		
KFB(S)1-4-S1	245 × 150 × 294 mm	9.6 × 5.9 × 11.6 in
KFB(S)1-W-4-S1		
KFB(S)1-6-S1		
KFB(S)1-W-6-S1		
Mounting position		vertical

EOP2-12

Electrical oil pump for the electrical single-line oil system (EOS) for chain lubrication

Features and benefits:

- Precise, metered quantities of oil reduce wear on chain and drive
- Metered quantities can be selected to match chain size and length as well as operating parameters
- 5 liter reservoir provides extended filling intervals
- Push-in fittings provide quick and easy installation

Function principle	Electrically operated gear pump
Lubricant	Mineral or biogredable oils
Operating viscosity	20-2000 mm ² /s
Delivery volume	150 cm ³ /min (0.347 pt/min)
Number of lubricant outlets	1
Capacity of the reservoir	5 l (1 gal)
Weight (empty pump)	4,4 kg (9 lb)
Operating pressure	max. 4 bar (58 psi)
Operating temperature	-10 to +70 °C (+14 to +189 °F)
Power supply	12 or 24 V DC
Protection class	IP 65
Dimensions	205 x 468 x 182,5 mm 8.07 x 18.4 x 7.18 inch
Mounting position	Vertical, i.e. lubricant reservoir at top



MOS/MOP 212 – MGP101

Mechanical oil and grease lubrication system

System benefits:

- Reduces wear on chains and chain drives with exact metered oil quantities
- Metered quantity is matched to chain size, length and demands
- Extended filling intervals with 5 l reservoir
- Mechanical drive – by means of the existing drive shaft of the machine, e. g. baler

Technical data MOS / MOP 212

- Pump elements with different outputs: 0,02; 0,04; 0,06 cm³
- 2 shaft types with different ratios (i = 7,7 and 19,53) to regulate lubricant that connect the drive shafts of the main unit
- 5 l reservoir
- Useable oils: Mineral oil, Ester base Bio oil
- Shaft connection :8 mm
- Rotational speed: 30–280 r/min
- Max. supply pressure: 10 bar
- Operating temperature: –10 to +70 °C
- Oil viscosity: 40 cSt to max. 2 000 cSt

Technical data MGP101

RPM range (via MOP 212):

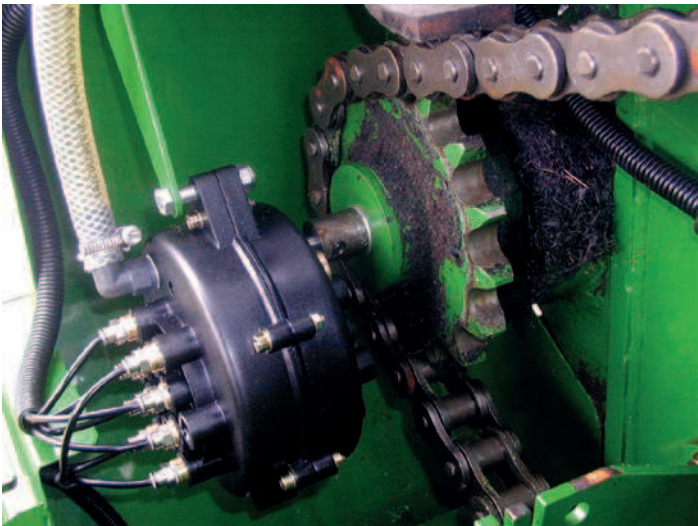

- shaft 1 (i = 19,53): 30 to 280 r/min
- shaft 2 (i = 7,7): 30 to 150 r/min or direct: up to 20 r/min
- Max. supply pressure: 200 bar
- Lubricant: Grease up to NLGI 2
- Output: 0,22 cm³/stroke



CONSTANTIN OSTAFIE – SKF CMP Inspector
Manager Fluid Power Department-Lubrication Systems & Rexroth

RULEXIM SRL – RO9837103 – j33/563/1997

Bd Sofia Vicoveanca 12, sat Bular, com Moara, Jud Suceava

727371 / Romania  

Tel: +40 230 514 888 / +40 230 514 999

Fax +40 230 511 233

Vodafone: +40 730 166 787

E-mail at: constantin.ostafie@rulexim.ro Visit us at: www.rulexim.ro

