

PROMOTIE SCULE PNEUMATICE



5% EXTRA DISCOUNT >10 BUCATI/COMANDA



CENTRUL NAȚIONAL de SCULE

1541 Pistol pneumatic 3/8"
Cod: 615320

271 Nm

PRET NET 581,00

- viteza de rotatie 10000 rot/min
- moment de torsiune max. 271 Nm
- presiunea maxima de aer comprimat: 6,2 Bar
- consum de aer comprimat 70 l/min
- racord de aer 1/4"
- capacitate maxima de strangere M10

1561 Pistol pneumatic 1/2"
Cod: 615322

814 Nm

PRET NET 573,00

- viteza de rotatie 8000 rot/min
- moment de torsiune max. 814 Nm
- presiunea maxima de aer comprimat: 6,2 Bar
- consum de aer comprimat 113 l/min
- racord de aer 1/4"
- capacitate maxima de strangere M16

1562 Pistol pneumatic 1/2"
Cod: 615321

949 Nm

PRET NET 728,00

- viteza de rotatie 6500 rot/min
- moment de torsiune max. 949 Nm
- presiunea maxima de aer comprimat: 6,2 Bar
- consum de aer comprimat 124 l/min
- racord de aer 1/4"
- capacitate maxima de strangere M18

1565 Pistol pneumatic si set de capete chei tubulare 1/2"
Cod: 615516

PRET NET 1093,00

- viteza de rotatie 6500 rot/min
- moment de torsiune max. 1085 Nm
- presiunea maxima de aer comprimat: 6,2 Bar
- consum de aer comprimat 198 l/min
- racord de aer 1/4"
- capacitate maxima de strangere M 24

1561 (1/2"), **231.4/4** (1/2" x 125, 1/2"x75), **231.8/4** (10 - 14, 15 - 32), **231/4 6p** (10, 13, 17, 19, 21, 22, 24, 27), **1374** (50ml), **231/4L6p** (17, 19, 21, 22, 24, 27)

1571 Pistol pneumatic 3/4"
Cod: 615324

1085 Nm

PRET NET 1286,00

- viteza de rotatie 6500 rot/min
- moment de torsiune max. 1085 Nm
- presiunea maxima de aer comprimat: 6,2 Bar
- consum de aer comprimat 198 l/min
- racord de aer 1/4"
- capacitate maxima de strangere M 24

1572 Pistol pneumatic 3/4"
Cod: 615323

1491 Nm

PRET NET 2036,00

- viteza de rotatie 5500 rot/min
- moment de torsiune max. 1491 Nm
- presiunea maxima de aer comprimat: 6,2 Bar
- consum de aer comprimat 269 l/min
- racord de aer 3/8"
- capacitate maxima de strangere M 30

Preturile reprezinta preturi nete de facturare exprimate in lei si nu contin TVA

Promotie valabila pana la 30 noiembrie 2017

Utilizati intotdeauna capete tubulare de impact!

Capetele tubulare de impact suporta un cuplu 100% mai mare decat o cheie standard cu clichet, de aceea cheile acestea sunt in mod deosebit potrivite pentru scule pneumatice care cer un cuplu ridicat.

1591 Pistol pneumatic 1"

Cod: 615325

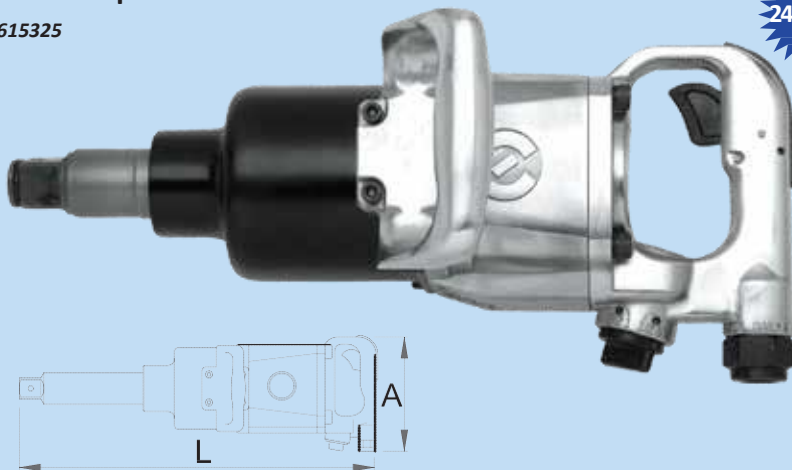

2439 Nm

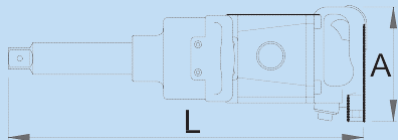

PRET
NET 2432,00

- viteza de rotatie 4000 rot/min
- momentul de torsiune max. 2439 Nm
- presiunea maxima de aer comprimat: 6,2 Bar
- consum de aer comprimat 255 l/min
- racord de aer 1/2"
- capacitate maxima de strangere M36



1514 Daltuitor pneumatic

170 mm

Cod: 617714

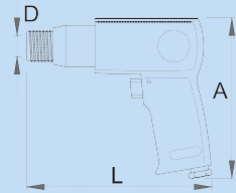
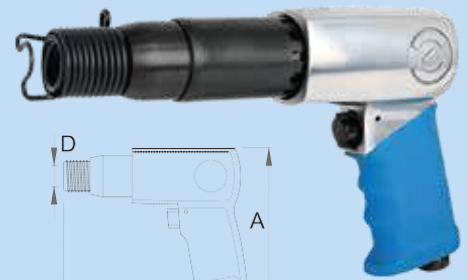

PRET
NET 214,00

- utilizat pentru taierea tablelor, bolturilor si curatirea suprafetelor sudate, nituri, ipsos si tigle
- cu arc, inlocuire rapida ca parte de schimb
- piston percutor lungime: 67 mm
- diametrul interior 9,1 mm
- lovituri pe minut: 3000 bpm
- consum de aer comprimat 250 l/min
- racord de aer 1/4"

1514 Daltuitor pneumatic

225 mm

Cod: 617715

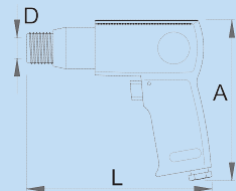
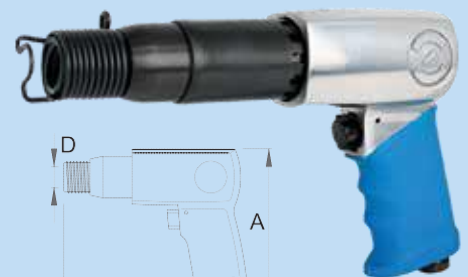

PRET
NET 251,00

- utilizat pentru taierea tablelor, bolturilor si curatirea suprafetelor sudate, nituri, ipsos si tigle
- cu arc, inlocuire rapida ca parte de schimb
- piston percutor lungime: 92 mm
- diametrul interior 9,1 mm
- lovituri pe minut: 2100 bpm
- consum de aer comprimat 250 l/min
- racord de aer 1/4"

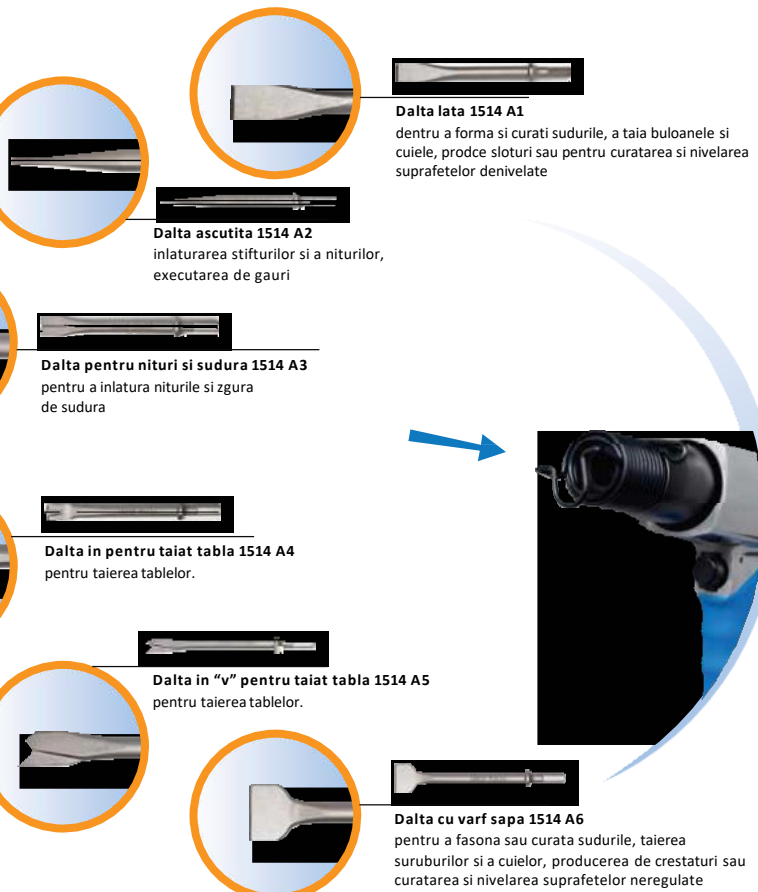

Dalta lata 1514 A1

dentru a forma si curati sudurile, a taia buloanele si cuiele, prodece sloturi sau pentru curatirea si nivelarea suprafetelor denivelate

Dalta ascutita 1514 A2

inlaturarea stifturilor si a niturilor, executarea de gauri

Dalta pentru nituri si sudura 1514 A3

pentru a inlatura niturile si zgura de sudura

Dalta in pentru taiat tabla 1514 A4

pentru taierea tablelor.

Dalta in "v" pentru taiat tabla 1514 A5

pentru taierea tablelor.

Dalta cu varf sapa 1514 A6

pentru a fasona sau curata sudurile, taierea suruburilor si a cuielei, producerea de crestari sau curatirea si nivelarea suprafetelor neregulate



Atentie!

- Cititi instructiunile inainte de a utiliza scula!
- Utilizati intotdeauna echipamentul de protectie!



Promotie valabila pana la 30 noiembrie 2017